

100 SERIES COIN MECHS



OPERATION EXPLANATIONS

The 100 Series Mechanical Coin Mechanism is designed to require a minimum of maintenance and field adjustment. Acceptance and rejection of coins or tokens is determined by size (both diameter and thickness), weight, metallic content and bounce.

- **The function of the Cradle** — Cradles are used to test the size and weight of the coin. Undersize diameter coins will pass between the legs of the cradle and will be returned. Oversize diameter coins will fail to pass between the cradle and the diameter gauge and will be returned by actuating the wiper lever. In the case of the U.S. quarter acceptor, an undersize lever must first be pivoted to unlock the cradle. Undersize diameter coins will fail to unlock the cradle and will be returned by actuating the wiper lever. Underweight coins will fail to overcome the cradle counterweight and will be returned by actuating the wiper lever. Coins that are oversize in thickness will fail to pass between the magnet gate and the mainplate and will have to be dislodged and returned by actuating the wiper lever.
- **The function of the Magnet** — A magnet is used to test the metallic content of the coin. Highly magnetic coins, such as steel or iron, will be retained by the magnet and will be returned by actuating the wiper lever. Coins having comparatively high magnetic properties, such as copper, will be slowed down by the magnet and will drop off the end of the rail, short of the kicker, and be returned. Coins having less magnetic properties, such as brass or zinc, will pass through the magnetic field quickly and will overshoot the separator and be returned.

Front View

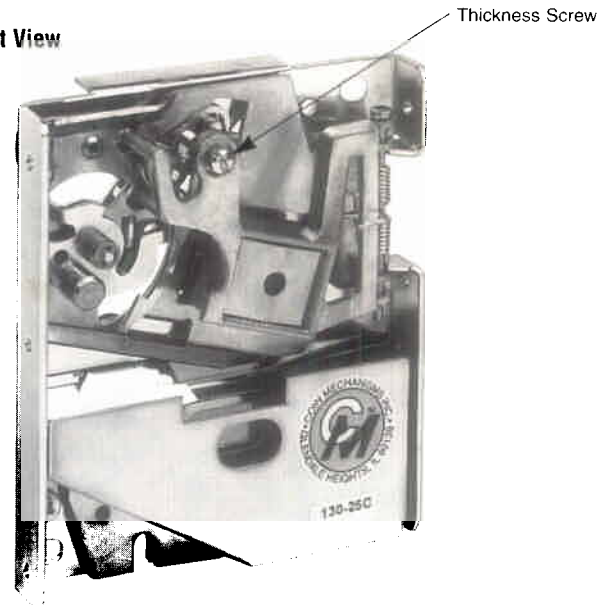

MAINTENANCE

Depending upon the environment in which the 100 Series Mechanism is used, periodic preventative maintenance should be performed.

The mainplate may be cleaned with any household cleanser. It is also possible to clean the entire mechanism by putting it in through the cycles in your dishwasher. The extreme heat used in the dry cycle will not harm the parts on the mech. In all cases, thorough rinsing and drying are necessary to remove deposits and/or film. Remove all filings and coin dust from the magnet by guiding the point of a screwdriver along the edges of the magnet. You will notice filings will cling to the point of the tool. Remove the cradle and undersize lever and clean the bushings. A pipe cleaner makes a good bushing cleaner. Also clean the pivot pin. Apply powdered graphite or pencil lead sparingly to the pivot and bushing reassemble.

Do not apply oils, grease, or WD-40 to the mechanism as these are dirt collectors.



COIN MECHANISMS INC. *The Name in Validation Systems*

P.O. Box 5128, 400 Regency Drive, Glendale Heights, IL 60139-5128
630/924-7070 • 1-800/323-6498 (In USA & Canada) • FAX 630/924-7088

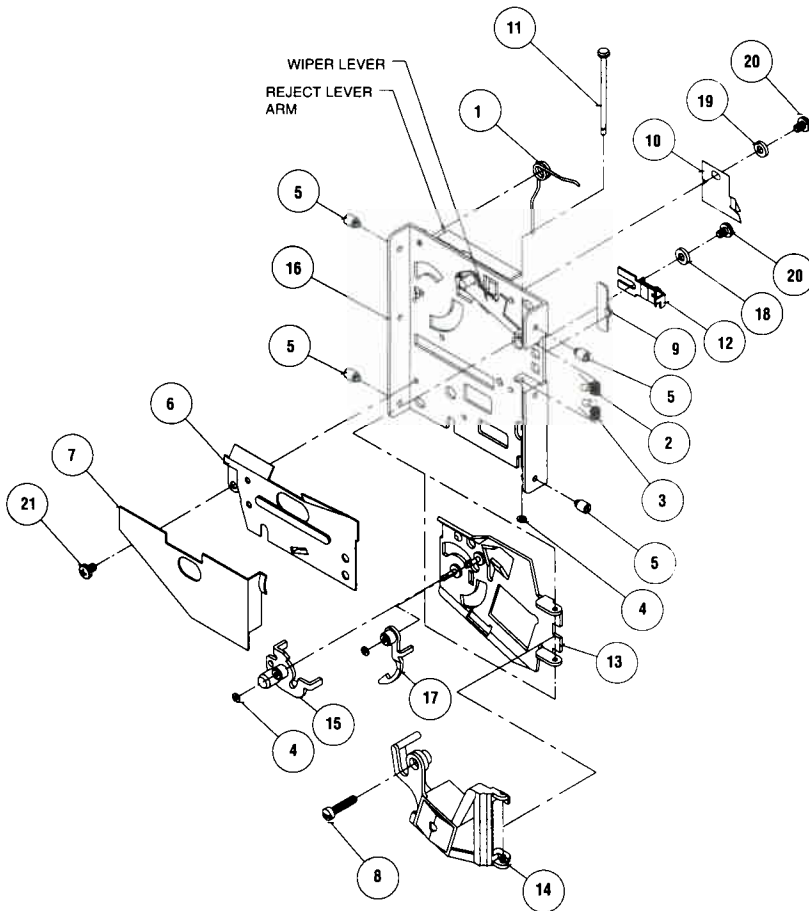

MATERIAL COLUMN			
ITEM	P/N	QTY	MATL DESCRIPTION
1	04050001	1	SPRING, OPERATING LEVER
2	04050002	1	SPRING, GATE, UPPER
3	04050003	1	SPRING, GATE, LOWER
4	04050007	3	RETAINER, "C" WASHER
5	04060005-01	4	STUD, #6 MTG
6	04100006-02	1	COVERPLATE, RETURN
7	04100012-02	1	COVERPLATE, 25C, "C", OVAL HOLE
8	04100040	1	SCREW, THICKNESS, 6-32 x 5/8
9	04100100-51	1	CLIP, SPRING SECURITY
10	04100104-11	1	CLUTTER, STRING
11	04100114	1	PIN, GATE PIVOT
12	05100001	1	SEPARATOR, ASSY
13	05100010	1	GATE, ASSY, STAKED, 25C
14	05100017	1	GATE, ASSY, MAGNET, GRN, 2LEG
15	05100021	1	CRADLE, ASSY, STAKED, .955
16	05100088	1	MAINPLATE, ASSY, STAKED, UNIVERSAL III
17	05100139	1	LEVER, ASSY, UNDERSIZE, 25C
18	600-6	1	WASHER, FLAT, 5/16 x 5/32, PHIL, #6
19	600-6-1	1	WASHER, FLAT, DOUBLE THICKNESS, #6
20	P-108-6-2-1/2	2	SCREW, 6-32 x 5/32, PHIL, BIND HEAD
21	P-190-6-2	1	SCREW, 6-32 x 1/8, PHIL, PH

ADJUSTMENTS

All 100 Series Mechanical Coin Mechanisms leave the factory adjusted for maximum performance. If more critical adjustments are desired, or if the unit has been completely disassembled for service, the following adjustment procedures are recommended:

Set the mechanism with the front of the unit facing you in the test position.

1. Magnet Casting Thickness Screw

This screw will only need to be turned if coins are getting stuck as they roll out of the cradle. To adjust, turn thickness screw counter clockwise several turns or until coin, when dropped in, hangs up near the magnet area. Then turn screw clockwise until coin just passes. Then turn screw 1/4 to 1/2 turn more.

2. Undersize Lever Adjustment (all mechanisms)

With a coin resting in the cradle slowly pivot the coin & cradle toward the undersize lever. The leg of the undersize lever should clear the cradle leg by a 1/16". To increase the clearance of the cradle, slightly bend the tab on the undersize lever toward the cradle.

3. Separator Assembly

- 1.) Loosen the screw holding the separator and move as far to the right as it will go. Tighten the screw.
- 2.) Insert several coins and note that some may miss or slightly touch the separator.
- 3.) Loosen the separator screw and move the separator a slight amount to the left. Tighten the screw.
- 4.) Insert the coins again and, if some of them are still returned, repeat Step 3 until all of the coins are accepted.