

Hamilton Manufacturing Corporation

1026 Hamilton Dr. Holland, OH 43528 • Phone: 419-867-4858/800-837-5561 • Fax: 419-867-4867 • www.hamiltonmfg.com

ACW-5 Operational Manual

IMPORTANT

PLEASE READ THIS MANUAL CAREFULLY PRIOR TO INSTALLING THIS UNIT. A complete understanding of the operation of this unit is essential for a successful installation.

ABOUT THIS MANUAL

This manual was designed to introduce the ACW-5 Auto Cashier and to provide general information about operation, installation and maintenance. This manual will enable the operator to program the ACW-5, perform audits, detect error codes and perform basic troubleshooting procedures. Also included are pre-programmed factory settings, Item Names and Welcome Messages, as well as a Tokenote® Training Guide for use with the optional Tokenotes®. Basic information is provided for the Hopper, Stacker and Validator. However, if additional information is needed for these components, refer to the appropriate manual. To obtain assistance from the manufacturer, please call (800) 837-5561 or (419) 867-4858. Or contact Hamilton Mfg. online @ <http://www.hamiltonmfg.com>.

When calling for assistance, it is important to have serial numbers readily available. Please take the time to record these numbers in the spaces provided.

ACW-5 SERIAL # _____

CONTROLLER SERIAL # _____

HOPPER SERIAL # _____

STACKER SERIAL # _____

VALIDATOR SERIAL # _____

LOCK / KEY # _____

Please complete the warranty card, which was included with your changer, and return it to the manufacturer.

TABLE OF CONTENTS

- I. INTRODUCTION.....8**

- II. OPERATION.....9 - 10**
 - NORMAL OPERATION..... 9**
 - STACKING WASHES..... 9 - 15**

- III. PROGRAMMABLE OPTIONS..... 11 - 15**
 - TOKEN COIN MODE? 11
 - TOKEN COIN VALUE?..... 11
 - TOKENOTE® MODE? 11
 - TOKENOTE® VALUE?..... 12
 - COUPON DISCOUNTS?..... 12
 - ITEM PRICES?..... 12
 - ITEM NAMES? 12
 - PROCEED PROMPTS? 12
 - WELCOME PROMPTS? 12
 - SET DATE & TIME?..... 13
 - VEND DURATION?..... 13
 - SET EMPTY MODE?..... 13
 - SET BUILD MODE? 13
 - SET PAY DEFAULT?..... 14
 - SET HOPPER STYLE? 14
 - SET DISPLAY STYLE?..... 14
 - SET BUTTON ENABLE?..... 15

- IV. AUDITS..... 16 - 17**
 - RESETTABLE AUDIT CATEGORIES 16**
 - NON-RESETTABLE AUDIT CATEGORIES 16**
 - INVENTORY and TOTAL DEPOSITS 16
 - INVENTORY and TOTAL VENDING 16
 - INVENTORY and TOTAL OVERPAID 17
 - AUDIT and TOTAL VAULT COUNT? 17
 - CLEAR RESETTABLE INVENTORIES?..... 17

- V. PROGRAMMING..... 18 - 37**
 - INVENTORY DEPOSITS? 21
 - INVENTORY VENDING? 22
 - INVENTORY OVERPAID?..... 22
 - AUDIT VAULT COUNT?..... 23
 - TOKEN COIN MODE? 24
 - TOKEN COIN VALUE?..... 24
 - TOKENOTE® MODE? 25
 - TOKENOTE® VALUE?..... 25

TABLE OF CONTENTS

COUPON DISCOUNTS?.....	26
ITEM PRICES?.....	26
ITEM NAMES?	27
PROCEED PROMPTS?	28
WELCOME PROMPTS?	29
PRINT REPORT?.....	30
SET DATE & TIME?.....	30
VEND DURATION?.....	31
SET EMPTY MODE?.....	31
SET BUILD MODE?.....	32
SET PAY DEFAULT?.....	32
SET HOPPER STYLE?.....	33
SET DISPLAY STYLE?.....	33
SET BUTTON ENABLE?	34
TOTAL DEPOSITS?.....	34
TOTAL VENDING?	35
TOTAL OVERPAID?.....	35
TOTAL VAULT COUNT?.....	36
CLEAR RESETTABLE INVENTORIES.....	37
VI. INSTALLATION / MAINTENANCE	38 - 48
MECHANICAL INSTALLATION	38 - 40
UNPACKING	38
POSITIONING	39
MOUNTING	39 - 40
RUNNING CONDUIT.....	40
Figure 1 - MOUNTING DETAILS A	41
Figure 2 - MOUNTING DETAILS B	42
ELECTRICAL INSTALLATION	43 - 45
PULLING WIRES	43
WIRE TERMINATIONS	43 - 45
SETTING THE CAR WASH CYCLE SYNCHRONIZATION SWITCH	45
PROGRAMMING CONTROLLER OPTIONS	45
GENERAL TEST	45
Figure 3 - RELAY PANEL	46
MAINTENANCE	47 - 48
MONTHLY MAINTENANCE	47 - 48
ANNUAL MAINTENANCE	48

TABLE OF CONTENTS

VII. ERROR CODES / TROUBLESHOOTING 49 - 57

ERROR CODES 49 - 52

 \$5 INPUT STUCK..... 49

 \$1 INPUT STUCK..... 49

 25¢ INPUT STUCK 50

 VALIDATOR SHUT DOWN..... 50

 TOKEN INPUT STUCK 50

 DROP SWITCH STUCK..... 50

 UNEXPECTED COIN DROP..... 50

 HOPPER COASTING ERROR..... 50

 HOPPER TIME-OUT 50

 STACKER TIME-OUT 50

 MULTIPLE POWER INT 50

 MEMORY DATA ALTERED! 51

 HOPPER EMPTY 51

 RELEASE BUTTON 51

 --PLEASE WAIT!---CAR WASH BUSY-- 52

 --OUT OF SERVICE---CAR WASH CLOSED— 52

TROUBLESHOOTING 53 - 57

 DISPLAY QUESTIONS 53

 MONEY ACCEPTANCE QUESTIONS 54 - 56

 HOPPER QUESTIONS 57

VIII. RETURNING ITEMS FOR SERVICE..... 58

IX. PARTS 59 - 61

APPENDICES

- APPENDIX A - Power Box / Relay Panel 62**
- APPENDIX B - Acw-4 Split Harness (Left Side) 63**
 - Acw-4 Split Harness (Right Side) 64**
 - Acw-4 Split Harness Legend 65 - 66**
- APPENDIX C - Tokenote Training Guide..... 67 - 75**
- APPENDIX D - Factory Programmed Settings 76**
- APPENDIX E - Pre-Programmed Item Names 77 - 78**
- APPENDIX F - Pre-Programmed Proceed Messages..... 79**
 - Pre-Programmed Welcome Messages 79**
- APPENDIX G - Installation / Mounting Instructions..... 80 - 83**

I. INTRODUCTION

The Hamilton Manufacturing ACW-5 is a totally automated car wash system with an easy to use customer interface.

The many benefits offered by an automated system include:

- Reduced personnel, and thus lower payroll.
- Increased security by eliminating the “silent partner” employee theft problem.
- Increased operating time as a result of a tireless customer interface that is capable of working 24 hours per day.

The following is a list of features for the ACW-5:

- A large, bright character display that welcomes customers and guides them through their transactions.
- It allows customers to select and pay for one of four possible washes, returning change if necessary.
- The ACW-5 has the ability to process a second customer’s transaction while the first customer is still in the bay receiving a wash. This eliminates long waits and increases revenue and customer satisfaction.
- The ACW-5 is capable of accepting Hamilton Tokenotes®. Tokenotes® are paper tokens that are inserted into the bill acceptor like dollar bills and used as credit towards the desired car wash selection.
- When used with an HV-X Validator (v3.19 or higher), the ACW-5 Controller has the ability to cycle the Stacker in an attempt to clear a possible bill jam.
- An Audible Beeper that is used to provide feedback to customers to help guide them through transactions.

The following optional equipment is available for use with the ACW-5:

- An External Display featuring a 3” x 18” display area. The External Display is used to display customized messages and to guide customers through transactions by displaying instructions in a large, bold fashion.
- Pre-formed bases that place the ACW-5 at the factory recommended height for various mounting situations.
- An ACW Lighted Hood, which is recommended if the ACW is mounted on a base.
- A hand-held printer used to receive a hard copy of all the audit information collected by the ACW-5.
- An Out of Service Relay Kit used to signal an auto-dialing modem to contact the owner if the unit goes into an error mode. (This kit only provides the signaling relay and does not include the actual auto-dialing modem.)

II. OPERATION

NORMAL OPERATION

When a customer drives up to the Auto Cashier, he is greeted by a bright display that welcomes and/or instructs him on how to proceed. At this point, the customer is able to do one of two things:

1. The customer may first select the wash desired by pressing one of the four wash selection buttons.
 - a. The display will alternate between the name of the wash selected and the amount of money to be deposited.
 - b. The message will remain until the wash has been paid for in full, with the amount displayed being updated after each deposit.
2. Or the customer may begin by depositing money or tokens to be used towards an upcoming wash selection.
 - a. The display will change to a constant message that shows the amount of credit that has been accumulated.
 - b. The customer must select one of the four wash selections.

Once the customer has made a wash selection and has deposited enough credit in money or tokens to pay for the wash, the transaction is complete. At this point, the ACW-5 will:

- Return any necessary change in quarters.
- Activate one of the four function relays to signal the car wash controller that a wash should begin.
- Signal the driver to proceed with the wash by displaying the Proceed Messages.
- After several seconds of displaying the message, the display will return to the sequencing Welcome Messages and the system prepares for the next transaction.

STACKING WASHES

If a second customer pulls up and begins purchasing a wash while another customer is in the wash bay receiving a wash, the previous operation differs slightly. This situation is known as "STACKING WASHES".

The operation for the STACKED WASH is listed below:

- The customer pulls up and views the Welcome Messages.
- The customer:
 - a. Deposits money or tokens, or
 - b. Makes a wash selection
- The customer completes the transaction by:
 - a. Making a selection, or
 - b. Depositing enough credit in money or tokens

At this point, since the previous car is still in the wash bay, the ACW will not display the Proceed Prompts. Instead, the display will show the alternating messages “PLEASE WAIT, CAR WASH IN USE”. These messages will be displayed until the first car leaves the wash bay (the car wash controller will notify the ACW-5 of this by pulsing its Cycle/Inhibit Relay). Once the wash bay is empty, the ACW-5 will signal the car wash as to which wash was selected and display the Proceed Messages. This lets the driver know that it is now okay to proceed into the car wash. After several seconds, the display will return to showing the Welcome Messages in preparation for the next customer.

III. PROGRAMMABLE OPTIONS

The ACW-5 has a number of programmable options that can be used by the car wash owner to customize the operation of the machine. These programmable options give the car wash owner the ability to:

- Set the desired prices
- Program custom messages
- Program the amount of credit given for token coins and/or Hamilton Tokenotes®

The following is a description of all of the programmable options, in the order they will be encountered in the PROGRAMMING MODE. For information on how to physically program the ACW-5, refer to the PROGRAMMING section.

- TOKEN COIN MODE?** The term “credit” is used to mean any non-cash form of payment. For the ACW-5 this includes token coins, Hamilton Tokenotes®, and debit or credit cards if the machine is so equipped. There are two choices for the TOKEN COIN MODE, MULTIPLE CREDITS and SINGLE CREDIT MODE. MULTIPLE CREDITS allows the customer to insert as many token coins as necessary to pay for the selected wash. The SINGLE CREDIT MODE, on the other hand, limits the customer to receiving credit for only one token coin per transaction. SINGLE CREDIT MODE is often used when token coins are distributed as a promotion to get customers to choose your car wash for reduced car wash rates. By only accepting one credit per customer, the customer will not be able to accumulate the promotional token coins and receive a free wash. In this mode, you will still be collecting some revenue on every car washed.
- TOKEN COIN VALUE?** The TOKEN COIN VALUE? category is used to program the amount of credit given when a token coin is accepted by the ACW-5. The value can be anything from \$0.00 to \$63.75 in \$0.25 increments. (Refer to APPENDIX C and the PROGRAMMING section for information on programming the TOKEN COIN VALUE.)
- TOKENOTE® MODE?** The term “credit” is used to mean any non-cash form of payment. For the ACW-5 this includes token coins, Hamilton Tokenotes®, and debit or credit cards if the machine is so equipped. There are two choices for the TOKENOTE® MODE, MULTIPLE CREDITS and SINGLE CREDIT MODE. MULTIPLE CREDITS allows the customer to insert as many Tokenotes® as necessary to pay for the selected wash. The SINGLE CREDIT MODE, on the other hand, limits the customer to receiving credit for only one Tokenote® per transaction. SINGLE CREDIT MODE is often used when Tokenotes® are distributed as a promotion to get customers to choose your car wash for reduced car wash rates. By only accepting one credit per customer, the customer will not be able to accumulate the promotional Tokenotes® and receive a free wash. In this mode, you will still be collecting some revenue on every car washed.

- TOKENOTE® VALUE?** The TOKENOTE® VALUE? category is used to program the amount of credit given when the Validator accepts a Tokenote® trained without a Training Coupon. The value can be anything from \$0.00 to \$63.75 in \$0.25 increments. (Refer to APPENDIX C and the PROGRAMMING section for information on programming the TOKENOTE® VALUE.)

- COUPON DISCOUNTS?** The COUPON DISCOUNTS? category is used to program the amount of credit given when a Tokenote®, trained with one of the four Training Coupons (Coupon #1 – 4), is accepted by the Validator. Each coupon code can have its own value that ranges from \$0.00 to \$63.75 in \$0.25 increments. (Refer to Appendix C and the PROGRAMMING section for information on programming the COUPON DISCOUNTS.)

- ITEM PRICES?** The ITEM PRICES? category is used to program the price of each of the four wash selections available on the ACW-5. The values can be anything from \$0.00 to \$63.75 in \$0.25 increments.

- ITEM NAMES?** The ITEM NAMES? category is used to assign a wash name to each of the four wash selections. These names may be chosen from a list of pre-programmed names or a custom name may be created. Up to eight different custom names can be programmed. If a ninth custom name is attempted, it overwrites the first custom name programmed. Once a custom name has been programmed, it will be listed along with the pre-programmed names when scrolling through the available wash name choices. These custom names can be deselected or overwritten, but never erased. Since it is a built in feature of the ACW-5 to display the wash name and the wash price whenever a wash selection button is pressed, it is recommended that a name be selected for all four washes.

- PROCEED PROMPTS?** The PROCEED PROMPTS? category is used to select the sequencing messages that are seen after a customer makes a wash selection and is waiting to proceed into the wash. There are up to four sequencing Proceed Prompts possible. These four messages may be chosen from a list of pre-programmed messages or a custom message may be created. (Refer to Appendix F for a list of pre-programmed messages.) Up to eight different custom messages can be programmed. If a ninth custom message is attempted, it overwrites the first custom message programmed. Once a custom message is programmed, it will be listed along with the pre-programmed messages when scrolling through the available message choices. These custom messages can be deselected or overwritten, but never erased. If you do not wish to use all four messages, simply program the desired messages with the pre-programmed or custom messages and program the remaining messages with the “ --- NOT USED ---” message located in the pre-programmed message list. This message will not appear on the screen. When this message is encountered in the message sequence, it automatically skips to the next message in the sequence without any time delay.

Proceed Prompts Example: To guide a customer through a transaction, the following messages may be selected:

PROCEED MESSAGE #1	“THANK YOU”
PROCEED MESSAGE #2	“PLEASE DRIVE AHEAD”
PROCEED MESSAGE #3	“--NOT USED--”
PROCEED MESSAGE #4	“--NOT USED--”

- WELCOME PROMPTS?** The WELCOME PROMPTS? category is used to select the sequencing messages that are seen when a customer first pulls up to the ACW-5. There are

up to four sequencing Welcome Messages possible. These four messages may be chosen from a list of pre-programmed messages or a custom message may be created. (Refer to Appendix F for a list of pre-programmed messages.) Up to eight different custom messages can be programmed. If a ninth custom message is attempted, it overwrites the first custom message programmed. Once a custom message is programmed, it will be listed along with the pre-programmed messages when scrolling through the available message choices. These custom messages can be deselected or overwritten, but never erased. If you do not wish to use all four messages, simply program the desired messages with the pre-programmed or custom messages and program the remaining messages with the “ --- NOT USED ---” message located in the pre-programmed message list. This message will not appear on the screen. When this message is encountered in the message sequence, it automatically skips to the next message in the sequence without any time delay.

Welcome Prompts Example: To guide a customer through a transaction, the following messages may be selected:

WELCOME MESSAGE #1	“WELCOME”
WELCOME MESSAGE #2	“PRESS ITEM BUTTON”
WELCOME MESSAGE #3	“OR DEPOSIT MONEY”
WELCOME MESSAGE #4	“---NOT USED---”

- SET DATE & TIME?** The SET DATE & TIME? category is used to program the current day, date and time. The time is programmed similar to the following example:

SAT_10-30-00_05:30_P

The day is selected followed by the month, date, and year, then the hour and minute, and finally the AM/PM specification.

- VEND DURATION?** The VEND DURATION? category is used to program the length of time that the ACW-5 turns on its vend relays. The vend relays get turned on to signal the car wash that the customer has finished the transaction and is ready to drive ahead. The length of time these relays should be held depends on the requirements of the particular car wash Controller being used. **Refer to your car wash manual before programming this setting.** The possible values range from 0.1 - 4.0 seconds.
- SET EMPTY MODE?** The SET EMPTY MODE? category is used to program how the ACW-5 will respond when the coin dispenser runs out of coins. There are two choices, OUT OF SERVICE and USE EXACT AMOUNT. If OUT OF SERVICE is selected and the Hopper goes empty, the display will stop showing the Welcome Messages and instead show the sequencing messages “OUT OF SERVICE” and “HOPPER EMPTY”. When this occurs, the bill acceptor and coin acceptors will be de-activated so no further transactions can occur until the Hopper is filled with coins. If USE EXACT AMOUNT is selected and the Hopper goes empty, the bill acceptor and coin acceptors will remain activated and the display will stop showing the Welcome Messages and instead show the sequencing messages “USE EXACT AMOUNT” and “NO CHANGE RETURNED”. In this mode, it is possible to continue performing transactions even though the Hopper is empty since the customer is being notified that no change will be returned and the exact amount must be deposited.
- SET BUILD MODE?** The SET BUILD MODE? category is used to enable or disable the Cash Buildup Limit feature. The two choices are LIMIT DISABLED and LIMIT ENABLED. If

LIMIT DISABLED is selected, a customer is able to build up credit indefinitely by continuing to deposit money. This can be undesirable if the customer is using the ACW-5 as a changer that will deplete the Hopper contents more rapidly than expected. However, if LIMIT ENABLED is selected, the maximum amount of cash buildup is limited by the price of the most expensive wash. This is accomplished by constantly comparing the amount of credit deposited and the four programmed wash prices. As soon as the credit amount is equal to or greater than the most expensive wash price, the ACW-5 deactivates the bill acceptor and coin acceptors so that no further deposits can be made until a wash is selected.

- SET PAY DEFAULT?** The SET PAY DEFAULT? mode is used when a fault is detected in one of the payment devices, such as the Validator or one of the coin acceptors. There are two options to choose from in this mode, USE ALT PAYMENT or OUT OF SERVICE. If a fault has been detected and the default payment mode is set to OUT OF SERVICE, the ACW will shut itself down until the error has been corrected. However, if the default payment mode is set to USE ALT PAYMENT, the ACW can continue operating, even if there is a fault in one or more of its payment devices. For example, a coin acceptor malfunctions, giving a constant payout pulse. In this situation, instead of shutting down the ACW, it will continue to operate but change the messages the customer sees. It will stop displaying the normal Welcome Messages and instead display the messages “PAYMENT OPTIONS...” and “USE BILLS ONLY”. This gives the customer the message not to use coins and tells the operator something has gone wrong with one of the coin acceptors and service is required. The ACW will continue to operate as long as there are payment options available. If all payment options are determined to be faulty, the machine will shutdown, displaying an error message for the last device to have a problem.

- SET HOPPER STYLE?** The SET HOPPER STYLE? category is used to program which type of Hamilton Hopper is being used in your ACW-5. Hoppers used in machines produced prior to January 1990 were Hamilton’s model HGP Hopper (“Old Style”). Hoppers used in machines after this date are Hamilton’s model HSH Hopper (“New Style”). The two choices for this category are “NEW STYLE HOPPER” or “OLD STYLE HOPPER”. If your ACW is older than January 1990 and has a model HGP Hopper, “OLD STYLE HOPPER” should be selected.

- SET DISPLAY STYLE?** The SET DISPLAY STYLE? category is used to program which display style is being used on your ACW-5. The current display being used on all Hamilton ACW’s is the single line display, which has a longer viewing area than the older two line style displays. Because of this, older cabinets designed for use with the two line displays cannot display all 20 characters available on the newer single line displays. This feature allows the operator to select the desired display style by choosing REGULAR (20 CHAR) for single line displays or RETROFIT (18 CHAR) for two line displays. **IT IS IMPORTANT TO REMEMBER THAT EACH TIME THE DISPLAY STYLE IS CHANGED, IT IS NECESSARY TO CLEAR OUT ANY PROGRAMMED MESSAGES. BECAUSE OF THIS IT WILL BE NECESSARY TO REPROGRAM ALL WELCOME MESSAGES, WASH NAMES, AND PROCEED PROMPTS EVERY TIME THE DISPLAY STYLE IS CHANGED. EXTERNAL DISPLAY MESSAGES ARE LEFT INTACT FOR DISPLAY STYLE CHANGES.**

- **SET BUTTON ENABLE?** The SET BUTTON ENABLE? category is used to program which buttons are enabled or disabled. Each of the four wash selection buttons, as well as the refund button, is selectable between enabled or disabled. If a button is enabled it will register as a valid selection if a customer should press that button. If a button is disabled, pressing it will have no affect. This is a valuable feature if only three washes are being utilized, or if the owner wishes to disable the refund button.

IV. AUDITS

For added security, the ACW-5 contains two complete sets of audits.

The RESETTABLE audit categories include:

- INVENTORY DEPOSITS?
- INVENTORY VENDING?
- INVENTORY OVERPAID?
- AUDIT VAULT COUNT?

The NON-RESETTABLE audit categories include:

- TOTAL DEPOSITS?
- TOTAL VENDING?
- TOTAL OVERPAID?
- TOTAL VAULT COUNT?

The information stored is the same for both sets. However, the RESETTABLE AUDITS are values accumulated since the last time the audits were cleared. The NON-RESETTABLE AUDITS contain values accumulated throughout the entire life of the Controller while it has been inside the ACW-5.

For details on how to view the audit information on your ACW-5, refer to the PROGRAMMING section. (It may be necessary to read the entire section to get a complete understanding of how the Controller functions.)

The information stored in each audit is described below.

- INVENTORY and TOTAL DEPOSITS** The DEPOSITS category shows a complete dollar amount of everything deposited into the machine, minus the change returned to the customer. It is broken down into three sub-categories, CASH, TOKENS and CARDS. The CASH deposit sub-category gives a total dollar amount of all \$1, \$5, \$10, \$20 bills and quarters deposited. It takes into consideration change that has been returned to the customer, displaying the amount of profit made. The TOKEN deposit sub-category gives a total dollar amount of all Tokenotes® and token coins deposited. The CARDS sub-category gives the total dollar amount of all WashCard®, debit card and credit card transactions, if applicable.
- INVENTORY and TOTAL VENDING** The VENDING category gives a complete breakdown of each wash purchased and the method of payment for each wash. It does this by showing the total amount of cash received in payment for each of the four washes as well as the dollar amount of token credit and debit card credit received. The VENDING category also takes into consideration the amount of change that has been returned to the customer, displaying the amount of profit made.

- ❑ **INVENTORY and TOTAL OVERPAID** The OVERPAID category totals the amount of change that could not be dispensed to customers. Most frequently, this category is adjusted when the Coin Hopper is empty and the ACW-5 is operating in the USE EXACT AMOUNT mode. If a customer deposits more than the selected wash price, the difference between the amount deposited and the selected wash price will be added to the overpaid categories.

- ❑ **AUDIT and TOTAL VAULT COUNT?** The VAULT COUNT category gives a complete breakdown of all deposits and cash payouts. It does this by offering specific counts on the number of each denomination bill that has been deposited, the number of each type of Tokenote® deposited, and the number of token coins, debit card approvals and quarters deposited. There is also a count of the number of quarters dispensed as change.

- ❑ **CLEAR RESETTABLE INVENTORIES?** Clearing the RESETTABLE INVENTORIES has the effect of zeroing out all values and counts that have been accumulated since the last time these inventories were cleared. The categories affected are INVENTORY DEPOSITS, INVENTORY VENDING, INVENTORY OVERPAID, and AUDIT VAULT COUNT. The NON-RESETTABLE categories remain unchanged. Refer to the PROGRAMMING section for details on how to clear the inventories.

V. PROGRAMMING

The ACW-5 comes pre-programmed from the factory. (Refer to Appendix D for the factory settings.) However, you may decide to program the ACW-5 to meet your individual needs.

☐ IN ORDER TO PROGRAM THE ACW-5, YOU MUST FIRST GAIN ACCESS TO THE CONTROLLER BY FOLLOWING THE STEPS BELOW:

1. Open the cabinet to view the Controller. It is positioned inside the large metal enclosure mounted on the lower right portion of the door.
2. To gain access to the Controller, remove the cover from the enclosure. (Refer to the directions printed on the enclosure.)
3. Once inside, the Controller is the piece of equipment that the wiring harness plugs into. (There is also a label to identify the Controller.)

☐ THERE ARE FOUR BUTTONS ON THE SIDE OF THE CONTROLLER THAT LOOK LIKE THIS:

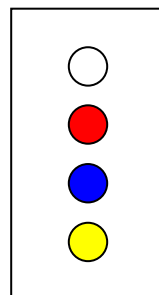

WHITE BUTTON – “RETURN”

RED BUTTON

BLUE BUTTON (OR BLACK)

YELLOW BUTTON – “ACTION”

☐ THE CONTROLLER HAS THREE LEVELS (OR “MODES”) OF OPERATION:

- **RUN MODE:** Where transactions are carried out with the customer. (Welcome Prompts are displayed.)
- **MENU MODE:** Scrolls through all of the programming categories. (Refer to pages 13-14 for a list of these categories and their definitions.)
- **PROGRAMMING MODE:** Scrolls through all of the messages or dollar amounts available for a particular category.

- THE FOLLOWING TABLE SHOWS THE FUNCTION OF EACH BUTTON AND HOW TO MOVE FROM MODE TO MODE.**

BUTTON	FUNCTION
WHITE - "RETURN"	Used to move up one MODE level at a time.
RED	Used to move down through the programming categories while in the MENU MODE, or to move through lists of messages or dollar amounts and to increase dollar amounts in the PROGRAMMING MODE.
BLUE or BLACK	Used to move up through the programming categories while in the MENU MODE, or to move through lists of messages or dollar amounts and to decrease dollar amounts in the PROGRAMMING MODE.
YELLOW - "ACTION"	Used to move down one MODE level at a time.

- IN ORDER TO PROGRAM THE ACW-5 IT IS NECESSARY TO:**

1. Have the machine turned on and running.
2. Have access to the four programming buttons on the side of the Controller.
3. Be able to view the display on the front of the machine.

- TO PROGRAM A PARTICULAR CATEGORY YOU MUST FOLLOW THE STEPS BELOW:**

1. Starting from the RUN MODE (Welcome Prompts), press the ACTION (YELLOW) button once. This will move you down one mode to the MENU MODE.
2. Using the RED and BLUE buttons, scroll through the different categories until you find the category you wish to change.
3. Once the desired category is displayed, use the ACTION (YELLOW) button to move down one mode to the PROGRAMMING MODE.
4. Using the RED and BLUE buttons, scroll through the messages or dollar amounts for that particular category until you find the desired selection.
5. Press the RETURN (WHITE) button twice to move up two modes and to return you to the RUN MODE (Welcome Prompt).
6. Or, if you wish to make a change to another category, press the RETURN (WHITE) button once to move up one mode to the MENU MODE. Repeat Step 4 for each category you wish to change.



Once a selection is displayed, it is automatically saved into the Controller's memory.

MENU MODE	
PROGRAMMING CATEGORIES	DESCRIPTIONS
INVENTORY DEPOSITS?	The amount taken in by the ACW-5 in cash, Tokenotes®, token coins, debit cards and credit cards.
INVENTORY VENDING?	Individual counts of the four wash selections.
INVENTORY OVERPAID?	The total change unable to be refunded while in the “USE EXACT AMOUNT” mode.
AUDIT VAULT COUNT?	Totals of each bill and coin denomination.
TOKEN COIN MODE?	Allows either single or multiple token use.
TOKEN COIN VALUE?	Amount of credit given for a valid token coin.
TOKENOTE® MODE?	Allows either single or multiple Tokenote® use.
TOKENOTE® VALUE?	Amount of credit given for a valid Tokenote®.
COUPON DISCOUNTS?	Amount of credit given for a valid coupon.
ITEM PRICES?	Amount of credit needed for each of the four washes.
ITEM NAMES?	Names that appear when each of the four washes are selected. Choose from pre-programmed Item Names or program custom names.
PROCEED PROMPTS?	Used to prompt the customer to proceed into the wash. Up to four Proceed Messages can be displayed. Choose from pre-programmed Proceed Prompts or program custom messages.
WELCOME PROMPTS?	Up to four sequencing messages displayed while system is enabled and in stand-by. Choose from pre-programmed Welcome Messages or program custom messages.
PRINT REPORT?	Prints report to optional portable printer.
SET DATE & TIME?	Sets current date and time in non-military format.
VEND DURATION?	Sets duration of vend relay closure.
SET EMPTY MODE?	Choice of shutting down (“OUT OF SERVICE”) or requesting exact change (“USE EXACT AMOUNT”) when Hopper is empty.
SET BUILD MODE?	Choice of enabling or disabling the Cash Buildup Limit feature.
SET PAY DEFAULT?	Choice of shutting down (“OUT OF SERVICE”) or giving payment options (“USE ALT PAYMENT”) when a fault has been detected in one of the payment devices.
SET HOPPER STYLE?	Used to configure system for either the Hamilton HGP or HSH Model Hopper (“Old Style Hopper” or “New Style Hopper”).
SET DISPLAY STYLE?	Used to set the number of characters displayed on the single line display.
SET BUTTON ENABLE?	Used to enable or disable each of the four wash selection buttons as well as the REFUND button.
MENU MODE	
PROGRAMMING	DESCRIPTIONS

CATEGORIES	
TOTAL DEPOSITS?	A cumulative non-resettable total of cash taken in and token credit (Tokenotes®, token coins, debit and credit cards).
TOTAL VENDING?	A cumulative non-resettable total of services performed.
TOTAL OVERPAID?	A cumulative non-resettable total of change unable to be refunded when in the "USE EXACT AMOUNT" mode.
TOTAL VAULT COUNT?	A cumulative non-resettable total of each bill denomination and coin.

The following section explains the programming steps required for each category. The categories will be listed in the order that they appear in the menu mode.

INVENTORY DEPOSITS?

TO VIEW THE INVENTORY DEPOSITS VALUES:

- Starting from the RUN MODE, press the ACTION (YELLOW) button to enter the MENU MODE. "INVENTORY DEPOSITS" is the first category so it should already be displayed.
- With Inventory Deposits appearing on the display, press the ACTION (YELLOW) button again. The display should read:

CASH = \$0.00

or

TOKENS = \$0.00

or

CARDS = \$0.00

* The dollar amounts shown are the current dollar, token and debit/credit totals.

- Use the ACTION (YELLOW) button to toggle between these values.
- When these values have been recorded, press the RETURN (WHITE) button once to return to the MENU MODE or twice to return to the RUN MODE.

INVENTORY VENDING?

TO VIEW THE INVENTORY VENDING VALUES:

- Starting from the RUN MODE, press the ACTION (YELLOW) button to enter the MENU MODE.
- Using the RED and BLUE buttons, scroll through the categories until “INVENTORY VENDING?” is displayed.
- Enter the PROGRAMMING MODE by pressing the ACTION (YELLOW) button. The display will read:

	VEND 1 CNT = 0	Number of Item 1 fees received
or	VEND 1 CSH = \$0.00	Number of Item 1 fees received in cash
or	VEND 1 TOK = \$0.00	Number of Item 1 fees received in Token Credit
or	VEND 1 DEB = \$0.00	Number of Item 1 fees received in debit or credit cards

- Use the ACTION (YELLOW) button to scroll through these values.
- When these values have been recorded, press the RETURN (WHITE) button once to return to the MENU MODE or twice to return to the RUN MODE.

INVENTORY OVERPAID?

TO VIEW THE INVENTORY OVERPAID VALUE:

- Starting from the RUN MODE, press the ACTION (YELLOW) button to enter the MENU MODE.
- Using the RED and BLUE buttons, scroll through the categories until “INVENTORY OVERPAID?” is displayed.
- Enter the PROGRAMMING MODE by pressing the ACTION (YELLOW) button. The display will read:

OVERPAID \$0.00

*The dollar amount shown is the current overpaid totals.

- When this information has been recorded, press the RETURN (WHITE) button once to return to the MENU MODE or twice to return to the RUN MODE.

AUDIT VAULT COUNT?

☐ TO VIEW THE AUDIT VAULT COUNT VALUES:

- Starting from the RUN MODE, press the ACTION (YELLOW) button to enter the MENU MODE.
- Using the RED and BLUE buttons, scroll through the categories until “AUDIT VAULT COUNT?” is displayed.
- Enter the PROGRAMMING MODE by pressing the ACTION (YELLOW) button. One of the following will be displayed:

\$20 BILL CNT	0
\$10 BILL CNT	0
\$5 BILL CNT	0
\$2 BILL CNT	0
\$1 BILL CNT	0
QUARTER CNT	0
TOKEN CNT	0
TOKENOTE CNT	0
COUPON 1 CNT	0
COUPON 2 CNT	0
COUPON 3 CNT	0
COUPON 4 CNT	0
HOPPER CNT	0

*The values shown are the current counts for each of these denominations.

- Press the ACTION (YELLOW) button to scroll through these displayed values.
- When this information has been recorded, press the RETURN (WHITE) button once to return to the MENU MODE or twice to return to the RUN MODE.

TOKEN COIN MODE?

☐ TO VIEW THE CURRENT TOKEN COIN MODE:

- Starting in the RUN MODE, press the ACTION (YELLOW) button to enter the MENU MODE.
- Using the RED and BLUE buttons, scroll through the categories until “TOKEN COIN MODE?” is displayed.
- Enter the PROGRAMMING MODE by pressing the ACTION (YELLOW) button. The display will read:

MULTIPLE CREDITS

or

SINGLE CREDIT MODE

*Depending on the current setting.

- Use the RED and BLUE buttons to toggle between the two settings.
- Press the RETURN (WHITE) button once to return to the MENU MODE or twice to return to the RUN MODE.

TOKEN COIN VALUE?

☐ TO VIEW THE CURRENT TOKEN COIN VALUE:

- Starting from the RUN MODE, press the ACTION (YELLOW) button to enter the MENU MODE.
- Using the RED and BLUE buttons, scroll through the categories until “TOKEN COIN VALUE?” is displayed.
- Enter the PROGRAMMING MODE by pressing the ACTION (YELLOW) button. The display will read:

TOKEN COIN = \$0.00

*The dollar amount is the current value.

- Using the RED and BLUE buttons, raise or lower the value in \$0.25 increments. The value can range from \$0.00 to \$63.75.
- When the desired value is displayed, press the RETURN (WHITE) button once to return to the MENU MODE or twice to return to the RUN MODE.

TOKENOTE® MODE?

☐ TO VIEW THE CURRENT TOKENOTE® MODE:

- Starting in the RUN MODE, press the ACTION (YELLOW) button to enter the MENU MODE.
- Using the RED and BLUE buttons, scroll through the categories until “TOKENOTE® MODE?” is displayed.
- Enter the PROGRAMMING MODE by pressing the ACTION (YELLOW) button. The display will read:

MULTIPLE CREDITS

or

SINGLE CREDIT MODE

*Depending on the current setting.

- Use the RED and BLUE buttons to toggle between the two settings.
- Press the RETURN (WHITE) button once to return to the MENU MODE or twice to return to the RUN MODE.

TOKENOTE® VALUE?

☐ TO VIEW THE CURRENT TOKENOTE® VALUE:

- Starting from the RUN MODE, press the ACTION (YELLOW) button to enter the MENU MODE.
- Using the RED and BLUE buttons, scroll through the categories until “TOKENOTE® VALUE?” is displayed.
- Enter the PROGRAMMING MODE by pressing the ACTION (YELLOW) button. The display will read:

TOKENOTE = \$0.00

*The dollar amount is the current value.

- Using the RED and BLUE buttons, raise or lower the value in \$0.25 increments. The value can range from \$0.00 to \$63.75.
- When the desired value is displayed, press the RETURN (WHITE) button once to return to the MENU MODE or twice to return to the RUN MODE.

COUPON DISCOUNTS?

TO VIEW THE CURRENT COUPON DISCOUNT VALUES:

- Starting from the RUN MODE, press the ACTION (YELLOW) button to enter the MENU MODE.
- Using the RED and BLUE buttons, scroll through the categories until “COUPON DISCOUNTS?” is displayed.
- Enter the PROGRAMMING MODE by pressing the ACTION (YELLOW) button. The display will read:

COUPON 1 = \$0.00

*The dollar amount is the current value for coupon #1.

- Using the RED and BLUE buttons, raise or lower the value in \$0.25 increments. The value can range from \$0.00 to \$63.75.
- When the desired value is displayed, you may program the next coupon or exit the PROGRAMMING MODE. To program the next coupon use the ACTION (YELLOW) button to scroll through each of the four Coupon Discounts and the RED and BLUE buttons to raise or lower the value. Repeat this step for each coupon you wish to program.
- Press the RETURN (WHITE) button once to return to the MENU MODE or twice to return to the RUN MODE.

ITEM PRICES?

TO VIEW THE CURRENT ITEM PRICES:

- Starting from the RUN MODE, press the ACTION (YELLOW) button to enter the MENU MODE.
- Using the RED and BLUE buttons, scroll through the categories until “ITEM PRICES?” is displayed.
- Enter the PROGRAMMING MODE by pressing the ACTION (YELLOW) button. The display will read:

ITEM 1 = \$0.00

*The dollar amount is the current wash #1 price.

- Using the RED and BLUE buttons, raise or lower the value in \$0.25 increments. The value can range from \$0.00 to \$63.75.
- When the desired value is displayed, you may program the next Item price or exit the PROGRAMMING MODE. To program, use the ACTION (YELLOW) button to scroll through each of the four Item Prices and the RED and BLUE buttons to raise or lower the value. Repeat this step for each Item Price you wish to program.
- Press the RETURN (WHITE) button once to return to the MENU MODE or twice to return to the RUN MODE.

ITEM NAMES?

☐ TO VIEW THE CURRENT ITEM NAMES:

- From the RUN MODE, press the ACTION (YELLOW) button to enter the MENU MODE.
- Using the RED and BLUE buttons, scroll through the categories until “ITEM NAMES?” is displayed.
- Enter the PROGRAMMING MODE by pressing the ACTION (YELLOW) button. The display will read:

ITEM #1 NAME

briefly, then

WASH & RINSE

*The second message displayed is the current Item #1 name.

- Use the RED and BLUE buttons to scroll through the factory pre-programmed names (refer to Appendix E for a complete list of pre-programmed Item Names).
- When the desired message is displayed, you may program the next Item Name or exit the PROGRAMMING MODE. To program, use the ACTION (YELLOW) button to scroll through each of the four Item Names and the RED and BLUE buttons to scroll through the factory pre-programmed names. Repeat this step for each Item Name you wish to program.
- Press the RETURN (WHITE) button once to return to the MENU MODE or twice to return to the RUN MODE.

☐ IF THERE IS NOT A PRE-PROGRAMMED NAME SUITABLE FOR YOUR APPLICATION, IT IS POSSIBLE TO PROGRAM A CUSTOM MESSAGE:

- Starting from the RUN MODE, enter the MENU MODE by pressing the ACTION (YELLOW) button.
- Use the RED and BLUE buttons to scroll through the categories until “ITEM NAMES?” is displayed.
- To enter the PROGRAMMING MODE, press the ACTION (YELLOW) button. This will bring up the Item #1 name.
- If the new custom message is not intended for Item #1, repeatedly press the ACTION (YELLOW) button until the proper item number is displayed.
- Using the RED and BLUE buttons, scroll through the pre-programmed names until a blank name is displayed.
- Press and hold the ACTION (YELLOW) button until a flashing cursor is displayed, then release the ACTION (YELLOW) button.
- Use the RED and BLUE buttons to move through the displayable letters and characters.
- Once the desired character or letter is displayed, move to the next space by pressing the ACTION (YELLOW) button.
- When the name is complete, press the RETURN (WHITE) button once to return to the MENU MODE or twice to return to the RUN MODE.

PROCEED PROMPTS?

- Starting in the RUN MODE, press the ACTION (YELLOW) button to enter the MENU MODE.
- Using the RED and BLUE buttons, scroll through the categories until “PROCEED PROMPTS?” is displayed.
- Enter the PROGRAMMING MODE by pressing the ACTION (YELLOW) button. The display will read:

PROCEED MESSAGE #1

briefly, then

PLEASE DRIVE AHEAD

*The second message displayed is the current Proceed Message #1.

- To change this message, use the RED and BLUE buttons to scroll through the factory pre-programmed messages (refer to Appendix F for a complete list of pre-programmed Proceed Messages).
- When the desired message is displayed, you may program the next message or exit the PROGRAMMING MODE. To program the next message, use the ACTION (YELLOW) button to scroll through each of the four Proceed Messages and the RED and BLUE buttons to scroll through the list of factory pre-programmed messages. Repeat this step for each Proceed Message you wish to program.
- Press the RETURN (WHITE) button once to return to the MENU MODE or twice to return to the RUN MODE.

☐ IF THERE IS NOT A PRE-PROGRAMMED MESSAGE SUITABLE FOR YOUR APPLICATION, IT IS POSSIBLE TO PROGRAM A CUSTOM MESSAGE:

- Starting from the RUN MODE, press the ACTION (YELLOW) button to enter the MENU MODE.
- Use the RED and BLUE buttons to scroll through the categories until “PROCEED PROMPTS?” is displayed.
- To enter the PROGRAMMING MODE, press the ACTION (YELLOW) button. This will bring up Proceed Message #1.
- If the new custom message is not intended for Message #1, press the ACTION (YELLOW) button until the proper message number is displayed.
- Using the RED and BLUE buttons, scroll through the pre-programmed messages until a blank message is displayed.
- Press and hold the ACTION (YELLOW) button until a flashing cursor is displayed, then release the ACTION (YELLOW) button.
- Use the RED and BLUE buttons to move through the displayable letters and characters.
- Once the desired character or letter is displayed, move to the next space by pressing the ACTION (YELLOW) button.
- When the message is complete, press the RETURN (WHITE) button once to return to the MENU MODE or twice to return to the RUN MODE.

WELCOME PROMPTS?

☐ TO VIEW THE CURRENT WELCOME PROMPT MESSAGES:

- From the RUN MODE, press the ACTION (YELLOW) button to enter the MENU MODE.
- Using the RED and BLUE buttons, scroll through the categories until “WELCOME PROMPTS?” is displayed.
- Enter the PROGRAMMING MODE by pressing the ACTION (YELLOW) button. The display will read:

WELCOME MESSAGE #1

briefly, then

SELECT SERVICE

*The second message displayed is the current Welcome Message #1.

- To change this message, use the RED and BLUE buttons to scroll through the factory pre-programmed messages. (Refer to Appendix F for a complete list of pre-programmed Welcome Messages.)
- When the desired message is displayed, you may program the next welcome message or exit the PROGRAMMING MODE. To program the next message, use the ACTION (YELLOW) button to scroll through each of the four Welcome Messages and the RED and BLUE buttons to scroll through the list of factory pre-programmed messages. Repeat this step for each Welcome Message you wish to program.
- Press the RETURN (WHITE) button to return to the MENU or RUN MODE.

☐ IF THERE IS NOT A PRE-PROGRAMMED MESSAGE SUITABLE FOR YOUR APPLICATION, IT IS POSSIBLE TO PROGRAM A CUSTOM MESSAGE:

- Starting from the RUN MODE, press the ACTION (YELLOW) button to enter the MENU MODE.
- Use the RED and BLUE buttons to scroll through the categories until “WELCOME PROMPTS?” is displayed.
- To enter the PROGRAMMING MODE, press the ACTION (YELLOW) button. This will bring up the Welcome Message #1.
- If the new custom message is not intended for Message #1, press the ACTION (YELLOW) button until the proper message number is displayed.
- Using the RED and BLUE buttons, scroll through the pre-programmed messages until a blank message is displayed.
- Press and hold the ACTION (YELLOW) button until a flashing cursor is displayed, then release the ACTION button.
- Use the RED and BLUE buttons to move through the displayable letters and characters.
- Once the desired character or letter is displayed, move to the next space by pressing the ACTION (YELLOW) button.
- When the message is complete, press the RETURN (WHITE) button once to return to the MENU MODE or twice to return to the RUN MODE.

PRINT REPORT?

TO GET A PRINTOUT OF THE ACW-5 AUDITS, IT IS NECESSARY TO:

- First connect a printer to the system.
- Then, starting from the RUN MODE, press the ACTION button to enter the MENU MODE.
- Using the RED and BLUE buttons, scroll through the categories until “PRINT REPORT?” is displayed.
- To start printing, press the ACTION button. The display will read:

PRINTING REPORT!

- When all information has been sent to the printer, the Controller returns to the MENU MODE. Press the RETURN button once to return to the RUN MODE.

THERE IS AN ALTERNATE METHOD OF OBTAINING A PRINTOUT OF THE ACW-5 AUDITS THAT DOES NOT REQUIRE ENTERING THE PROGRAMMING MODE. TO DO THIS:

- First connect a printer to the system.
- Then, with the printer turned ON, press the “ON-LINE” button on the printer four times in quick succession. The printer will begin printing and the display will read:

TRANSMITTING DATA!

- When all information has been sent to the printer, the Controller returns to displaying the Welcome Messages.

SET DATE & TIME?

TO VIEW THE DATE AND TIME:

- Starting from the RUN MODE, press the ACTION (YELLOW) button to enter the MENU MODE.
- Using the RED and BLUE buttons, scroll through the categories until “SET DATE & TIME” is displayed.
- Enter the PROGRAMMING MODE by pressing the ACTION (YELLOW) button. The display will read:

SAT 10-28-00 05:30 P

- There will be a flashing cursor on the day setting. This is the current day of the week. To change this, use the RED and BLUE buttons to adjust the day.
- When the correct day is displayed, press the ACTION (YELLOW) button to program the current month. The cursor will move to the first pair of numbers. Use the RED and BLUE buttons to adjust the month.
- Follow this same sequence to program the current date, year, hour, minute, and the AM/PM setting.
- When the correct day, date, and time are displayed, press the RETURN (WHITE) button once to return to the MENU MODE or twice to return to the RUN MODE.

VEND DURATION?

☐ TO VIEW THE CURRENT VEND DURATION TIME:

- Starting from the RUN MODE, press the ACTION (YELLOW) button to enter the MENU MODE.
- Using the RED and BLUE buttons, scroll through the categories until “VEND DURATION?” is displayed.
- Enter the PROGRAMMING MODE by pressing the ACTION (YELLOW) button. The display will read:

VEND PULSE = 1.0s

*The value shown is the current time in seconds.

- To change this value, use the RED and BLUE buttons to raise or lower the value in 0.1 second increments. The factory recommended setting is 2.0 seconds, however, REFER TO YOUR CAR WASH MANUAL FOR THEIR RECOMMENDATION BEFORE PROGRAMMING THIS SETTING.
- When the desired value is displayed, press the RETURN (WHITE) button once to return to the MENU MODE or twice to return to the RUN MODE.

SET EMPTY MODE?

☐ TO VIEW THE CURRENT EMPTY MODE:

- Starting from the RUN MODE, press the ACTION (YELLOW) button to enter the MENU MODE.
- Using the RED and BLUE buttons, scroll through the categories until “SET EMPTY MODE?” is displayed.
- Enter the PROGRAMMING MODE by pressing the ACTION (YELLOW) button. The display will read:

USE EXACT AMOUNT

or

OUT OF SERVICE

*Depending on the current setting.

- Use the RED and BLUE buttons to toggle between the two settings.
- Press the RETURN (WHITE) button once to return to the MENU MODE or twice to return to the RUN MODE.

SET BUILD MODE?

TO VIEW THE CURRENT BUILD MODE:

- Starting from the RUN MODE, press the ACTION (YELLOW) button to enter the MENU MODE.
- Using the RED and BLUE buttons, scroll through the categories until “SET BUILD MODE?” is displayed.
- Enter the PROGRAMMING MODE by pressing the ACTION (YELLOW) button. The display will read:

LIMIT ENABLED

or

LIMIT DISABLED

*Depending on the current setting.

- Use the RED and BLUE buttons to toggle between the two settings.
- Press the RETURN (WHITE) button once to return to the MENU MODE or twice to return to the RUN MODE.

SET PAY DEFAULT?

TO VIEW THE CURRENT PAYMENT MODE:

- Starting in the RUN MODE, press the ACTION (YELLOW) button to enter the MENU MODE.
- Using the RED and BLUE buttons, scroll through the categories until “SET PAY DEFAULT?” is displayed.
- Enter the PROGRAMMING MODE by pressing the ACTION (YELLOW) button. The display will read:

OUT OF SERVICE

or

USE ALT PAYMENT

*Depending on the current setting.

- Use the RED or BLUE buttons to toggle between the two settings.
- Press the RETURN (WHITE) button once to return to the MENU MODE or twice to return to the RUN MODE.

SET HOPPER STYLE?

☐ TO VIEW THE CURRENT HOPPER STYLE:

- Starting in the RUN MODE, press the ACTION (YELLOW) button to enter the MENU MODE.
- Using the RED and BLUE buttons, scroll through the categories until “SET HOPPER STYLE?” is displayed.
- Enter the PROGRAMMING MODE by pressing the ACTION (YELLOW) button. The display will read:

OLD STYLE HOPPER

or

NEW STYLE HOPPER

*Depending on the current setting.

- Use the RED or BLUE buttons to toggle between the two settings.
- Press the RETURN (WHITE) button once to return to the MENU MODE or twice to return to the RUN MODE.

SET DISPLAY STYLE?

☐ TO VIEW THE CURRENT DISPLAY STYLE:

- Starting from the RUN MODE, press the ACTION (YELLOW) button to enter the MENU MODE.
- Using the RED and BLUE buttons, scroll through the categories until “SET DISPLAY STYLE” is displayed.
- Enter the PROGRAMMING MODE by pressing the ACTION (YELLOW) button. The display should read:

REGULAR (20 CHAR)

or

RETROFIT (18 CHAR)

*Depending on the current setting.

- Use the RED or BLUE buttons to toggle between the two settings.
- Press the RETURN (WHITE) button once to return to the MENU MODE or twice to return to the RUN MODE.

SET BUTTON ENABLE?

☐ TO VIEW THE CURRENT ENABLE SETTING:

- Starting from the RUN MODE, press the ACTION (YELLOW) button to enter the MENU MODE.
- Using the RED and BLUE buttons, scroll through the categories until “SET BUTTON ENABLE?” is displayed.
- Enter the PROGRAMMING MODE by pressing the ACTION (YELLOW) button. The display should read:

BUTTON 1 = ENABLE

or

BUTTON 1 = DISABLE

*Depending on the current setting.

- Use the RED or BLUE buttons to toggle between the two settings.
- When the desired message is displayed, you may program the next button or exit the PROGRAMMING MODE. To program, use the ACTION (YELLOW) button to scroll through each of the button categories and the RED and BLUE buttons to toggle between the settings.
- Press the RETURN (WHITE) button once to return to the MENU MODE or twice to return to the RUN MODE.

TOTAL DEPOSITS?

☐ TO VIEW THE TOTAL DEPOSITS VALUES:

- Starting from the RUN MODE, press the ACTION (YELLOW) button to enter the MENU MODE.
- Using the RED and BLUE buttons, scroll through the categories until “TOTAL DEPOSITS” is displayed.
- Enter the PROGRAMMING MODE by pressing the ACTION (YELLOW) button. The display should read:

CASH = \$0.00

or

TOKENS = \$0.00

or

CREDITS = \$0.00

* The dollar amounts shown are the current dollar, token and debit/credit totals.

- To toggle between these values press, the ACTION (YELLOW) button.
- When these values have been recorded, press the RETURN (WHITE) button once to return to the MENU MODE or twice to return to the RUN MODE.

TOTAL VENDING?

TO VIEW THE TOTAL VENDING VALUES:

- Starting from the RUN MODE, press the ACTION (YELLOW) button to enter the MENU MODE.
- Using the RED and BLUE buttons, scroll through the categories until “TOTAL VENDING?” is displayed.
- Enter the PROGRAMMING MODE by pressing the ACTION (YELLOW) button. The display will read:

VEND 1 CNT = 0

Number of Item 1 fees received

or

VEND 1 CSH = \$0.00

Number of Item 1 fees received in cash

or

VEND 1 TOK = \$0.00

Number of Item 1 fees received in token credit

or

VEND 1 DEB = \$0.00

Number of Item 1 fees received in debit or credit cards

- Use the ACTION (YELLOW) button to scroll through these values.
- When these values have been recorded, press the RETURN (WHITE) button once to return to the MENU MODE or twice to return to the RUN MODE.

TOTAL OVERPAID?

TO VIEW THE TOTAL OVERPAID VALUE:

- Starting from the RUN MODE, press the ACTION (YELLOW) button to enter the MENU MODE.
- Using the RED and BLUE buttons, scroll through the categories until “TOTAL OVERPAID?” is displayed.
- Enter the PROGRAMMING MODE by pressing the ACTION (YELLOW) button. The display will read:

OVERPAID \$0.00

*The dollar amount shown is the current overpaid totals.

- When this information has been recorded, press the RETURN (WHITE) button once to return to the MENU MODE or twice to return to the RUN MODE.

TOTAL VAULT COUNT?

☐ TO VIEW THE TOTAL VAULT COUNT VALUES:

- Starting from the RUN MODE, press the ACTION (YELLOW) button to enter the MENU MODE.
- Using the RED and BLUE buttons, scroll through the categories until “TOTAL VAULT COUNT?” is displayed.
- Enter the PROGRAMMING MODE by pressing the ACTION (YELLOW) button. One of the following will be displayed:

\$20 BILL CNT	0
\$10 BILL CNT	0
\$5 BILL CNT	0
\$2 BILL CNT	0
\$1 BILL CNT	0
QUARTER CNT	0
TOKEN CNT	0
TOKENOTE CNT	0
COUPON 1 CNT	0
COUPON 2 CNT	0
COUPON 3 CNT	0
COUPON 4 CNT	0
HOPPER CNT	0

*The values shown are the current counts for each of these denominations.

- Press the ACTION (YELLOW) button to scroll through these displayed values.
- When this information has been recorded, press the RETURN (WHITE) button once to return to the MENU MODE or twice to return to the RUN MODE.

CLEAR RESETTABLE INVENTORIES

☐ TO CLEAR THE INVENTORIES:

- Starting from the RUN MODE, first press the ACTION (YELLOW) button to enter the MENU MODE.
- Using the RED and BLUE buttons, scroll through the categories until any of the “INVENTORY” categories are displayed.
- Next, press the ACTION (YELLOW) button to enter the PROGRAMMING MODE and to display the contents of the category entered.
- At this point, press and hold both the RED and BLUE buttons until the display reads:

CLEAR INVENTORIES?

- Release both buttons. When both buttons have been released, the display will begin sequencing through the following messages:

CLEAR INVENTORIES?

ACTION TO CLEAR

OR RETURN TO ABORT

- This message sequence will continue until either the ACTION (YELLOW) button or the RETURN (WHITE) button is pressed.
- If the ACTION (YELLOW) button is pressed, the display will read:

MEMORY CLEARED!

briefly, then return to the beginning of the MENU MODE.

- If the RETURN (WHITE) button is pressed, the display will read:

MEMORY NOT CLEARED

briefly, then return to the beginning of the MENU MODE.

- Press the RETURN (WHITE) button once to return to the RUN MODE.

VI. INSTALLATION / MAINTENANCE

★ **It is very important to read and understand all of these instructions before attempting installation.**

The installation process contains two distinct operations, **MECHANICAL INSTALLATION**, and **ELECTRICAL INSTALLATION**.

THE MECHANICAL INSTALLATION INVOLVES:

- Unpacking the machine
- Positioning the ACW-5 Unit
- Mounting the ACW-5 Unit
- Running wiring conduits to the car wash

THE ELECTRICAL INSTALLATION INVOLVES:

- Running the necessary wiring
- Making the proper wiring terminations
- Correctly setting the Car Wash Cycle Synchronization Switch
- Setting the PROGRAMMABLE OPTIONS
- Performing a General Systems Test

The following sections provide detailed explanations for each of these installation procedures.

A. MECHANICAL INSTALLATION

1. UNPACKING

There are a number of things to keep in mind while unpacking your ACW-5 that will make the installation and continued operation of your machine run smoother. These tips are listed below.

BE SURE TO SAVE YOUR KEYS

The keys and lock inserts are placed inside a small cloth bag attached to the outside of the machine in a visible, secured spot. This bag should be located between the layers of shrink-wrap that encircle the outside of the cabinet. When removing this shrink-wrap, be sure to locate the bag containing the keys and set it aside so it does not get thrown away. **MAKE A PERMANENT RECORD OF THE NUMBERS ON YOUR KEYS IN CASE A KEY IS LOST AND MUST BE REORDERED.**

REMOVE THE PACKING STRAP FROM THE VALIDATOR

The Validator comes shipped with a packing strap secured around it to minimize the vibrations of shipping. If this strap is not removed, a high bill rejection rate could result. The strap may be cut off with a pair of wire cutters or sturdy scissors.

LOOSEN THE VALIDATOR THUMBSCREW

The Validator comes shipped with a tightly secured thumbscrew that holds the Validator to the Validator Bracket. This is to minimize the vibrations caused by shipping. This thumbscrew should be loosened three full turns. If the thumbscrew is not loosened, bill stealing or Stacker jamming could result. The screw may be loosened by hand or with a small pair of pliers.

REMOVE THE PACKING STRAP FROM THE HOPPER

The Hopper comes shipped with a packing strap secured around it to minimize the vibrations caused by shipping. If this strap is not removed, the Hopper will not tip out for easy filling. The strap may be cut off with a pair of wire cutters or sturdy scissors. Cardboard is placed around the edges of the Hopper to protect it during shipping. After removing the strap, be sure to remove the cardboard as well.

REMOVE ALL PACKING DEBRIS FROM THE HOPPER

During packing and unpacking, it is possible for debris to fall into the Hopper Bowl (the area where the coins go). If this material is not removed, Hopper jamming could occur. With the power completely disconnected, remove all loose material inside the Hopper Bowl.

FILL HOPPER WITH COINS

Before powering up the machine for the first time, it is recommended that the Hopper be filled with coins. In order for the Hopper to dispense coins, there must be enough coins in the Hopper Bowl to touch the two sensing plates located at the bottom of the bowl. Otherwise, the Hopper will register as empty.

INSERT SAMPLE COIN

In order for the Auto Cashier to start accepting coins, a sample coin must first be inserted into the Slugbuster. The Slugbuster is located on the inside of the cabinet door. There is a sliding mechanism on the Slugbuster identified by a round sticker that reads "Slide To Replace Coin". Simply slide this mechanism to the right and insert the sample coin. The mechanism will slide back into place on its own. The Auto Cashier is now ready to accept coins.

2. POSITIONING

There are no set guidelines for the placement of the ACW-5. However, it is recommended that the machine is positioned far enough away from the wash entrance to minimize the amount of overspray that may get into the ACW-5. Also, there is a typical height, from the pavement to the bottom of the cabinet, of approximately 26" (see Figure 2).

3. MOUNTING

It is recommended that the ACW-5 be mounted in a permanent enclosure. Safety is a primary concern, so the equipment must be securely mounted. Hamilton recommends using one of the following methods:

- The first method is to construct a small brick or concrete kiosk that will house the Auto Cashier. Figure 1 and Figure 2 give the ACW-5 mounting hole locations as well as suggested kiosk dimensions. **Have your engineer or contractor recommend construction suitable for strength and stability.** For an illustration of this mounting procedure, refer to APPENDIX G.
- The other method involves mounting the ACW-5 on the optional ACW Base described in the INTRODUCTION section. In this situation, the base is secured to the pavement and the ACW-5 is secured to the base. **Fasteners to be used should be recommended by your engineer as to strength and suitability.** If this method is chosen, it is strongly recommended that the optional ACW Lighted Cap be installed. This addition serves to better insulate the ACW-5 from harsh environmental conditions as well as offering an attractive lighted top. Contact Hamilton Mfg. for installation instructions for the ACW Lighted Cap.

★ **Hamilton will not be responsible for injury due to improper installation.**

4. RUNNING CONDUIT

Typical electrical code requires low and high voltage wiring to be run in separate conduits. Because of this, the ACW-5 has two $\frac{3}{4}$ " conduit mounting holes in the back of the cabinet, as well as two $\frac{3}{4}$ " and one $\frac{1}{2}$ " conduit holes in the bottom of the cabinet. These bottom holes are matched with identical holes in any of the optional ACW Bases offered by Hamilton Mfg.

★ **At least one bottom hole must remain unused at all times.**

- Conduit carrying high voltage 120VAC power lines, as well as any signal lines containing 120VAC, should be connected to the center mounting hole on the back wall of the ACW-5, or any one of the bottom mounting holes.
- Conduit carrying lines with 24VAC, 24VDC, 12VAC or 12VDC signals should be connected to the mounting hole on the right side of the back wall (when viewed from the front of the machine), or any unused bottom mounting hole.

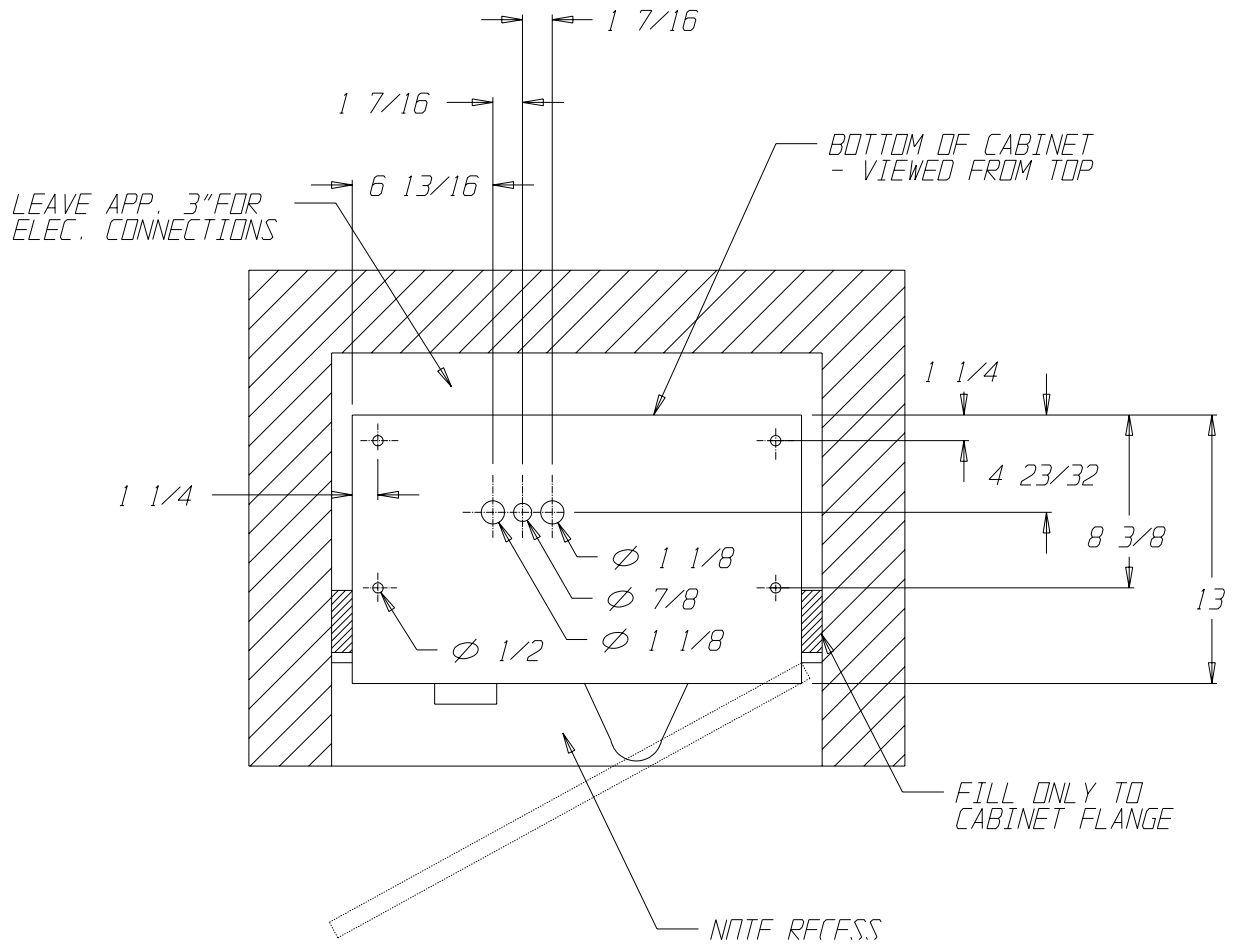

Figure 1
MOUNTING DETAILS A
 (all dimensions in inches)

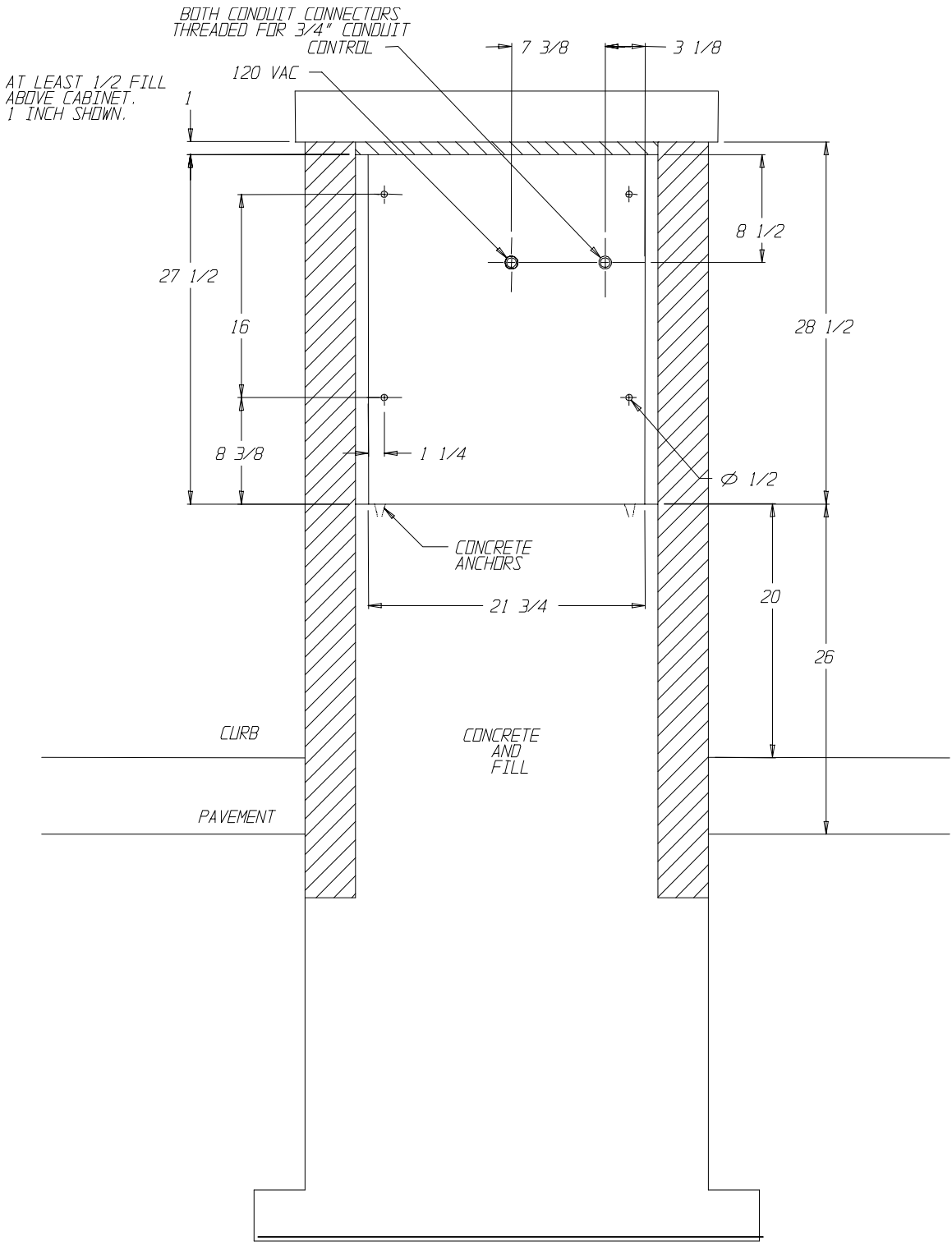

Figure 2
MOUNTING DETAILS B
 (all dimensions in inches)

B. ELECTRICAL INSTALLATION

This auto cashier is operated on 120 VAC, 60 Hz. This unit uses a 5 AMP CIRCUIT BREAKER. Unit may be hard-wired with conduit if desired.

A GROUND FAULT INTERRUPTER IS REQUIRED. The recommended Ground Fault Interrupter is sometimes referred to as an ELCI (Equipment Leakage Circuit Interrupter) and should have the following specifications:

- 120 VAC
- 15 AMP
- 6-10mA trip level
- Should **not** trip when power is removed from circuit.

1. PULLING WIRES

- THE NUMBER AND TYPE OF WIRES NEEDED TO BE PULLED FOR THE ACW-5 SYSTEM IS SHOWN BELOW.**

WIRES	WIRE GAUGE	WIRE DESCRIPTION	WIRE COLOR
3	14 AWG OR LOCAL CODE SPECIFICATION	120VAC HOT, NEUTRAL, EARTH GROUND	BLK, WHT, GRN
*2	20 AWG	ITEM 1 SIGNAL ITEM 1 RETURN	ANY COLOR
*2	20 AWG	ITEM 2 SIGNAL ITEM 2 RETURN	ANY COLOR
*2	20 AWG	ITEM 3 SIGNAL ITEM 3 RETURN	ANY COLOR
*2	20 AWG	ITEM 4 SIGNAL ITEM 4 RETURN	ANY COLOR
2	20 AWG	CYCLE / INHIBIT COIL CYCLE / INHIBIT COIL	ANY COLOR

*It is also acceptable to run 1 common line, which is then connected to all ITEM RETURN lines.

For proper operation of the ACW-5, all wires listed above must be pulled and terminated as explained in the following section, WIRE TERMINATIONS.

2. WIRE TERMINATIONS

- THE WIRE TERMINATIONS SHOULD PROCEED AS FOLLOWS:**

- 1) One side of the three power supply wires (120VAC HOT, 120VAC NEU, and 120VAC GND) should be attached directly to the electrical service panel supplying power to the installation. They should be connected to a 15 AMP circuit breaker and the ACW-5 should be the only device on this circuit. The other end of these three wires should be routed into the ACW-5 through the installed conduit. The wires should be terminated

using wire-nuts so that each of the colors (WHT, BLK, and GRN) mates with the same color wire coming from within the service box connected to the Relay Panel of the ACW-5.

- 2) The ITEM 1 wire pair (ITEM 1 SIGNAL and ITEM 1 RETURN) is used to signal the wash controller that a customer has completed a transaction and has selected the Wash #1 sequence. The signal presented to the car wash controller is a normally open, dry contact relay closure. In the ACW-5, connect one end of this pair to terminals 1 and 2 on the Relay Panel terminal block. Refer to your car wash controller literature for proper connections on the other end of this pair.
- 3) The ITEM 2 wire pair (ITEM 2 SIGNAL and ITEM 2 RETURN) is used to signal the wash controller that a customer has completed a transaction and has selected the Wash #2 sequence. The signal presented to the car wash controller is a normally open, dry contact relay closure. In the ACW-5, connect one end of this pair to terminals 3 and 4 on the Relay Panel terminal block. Refer to your car wash controller literature for proper connections on the other end of this pair.
- 4) The ITEM 3 wire pair (ITEM 3 SIGNAL and ITEM 3 RETURN) is used to signal the wash controller that a customer has completed a transaction and has selected the Wash #3 sequence. The signal presented to the car wash controller is a normally open, dry contact relay closure. In the ACW-5, connect one end of this pair to terminals 5 and 6 on the Relay Panel terminal block. Refer to your car wash controller literature for proper connections on the other end of this pair.
- 5) The ITEM 4 wire pair (ITEM 4 SIGNAL and ITEM 4 RETURN) is used to signal the wash controller that a customer has completed a transaction and has selected the Wash #4 sequence. The signal presented to the car wash controller is a normally open, dry contact relay closure. In the ACW-5, connect one end of this pair to terminals 7 and 8 on the Relay Panel terminal block. Refer to your car wash controller literature for proper connections on the other end of this pair.
- 6) The CYCLE/INHIBIT pair is used for the car wash controller to signal the ACW-5 when a car has completed its wash and has left the bay. The signal coming from the car wash controller must be able to energize the coil of a relay on the Relay Panel. This means that the car wash controller is supplying both voltage and current when it energizes the coil. Inside the ACW, the wiring connections depend on the signal provided by the car wash controller.
 - If the externally supplied signal is a 120VAC signal, the CYCLE/INHIBIT pair should be connected to the two RED wires coming from the service box connected to the Relay Panel. This connection is made by using wire-nuts to connect the CYCLE/INHIBIT SIGNAL to one of the RED wires (it doesn't matter which one), and connecting the CYCLE/INHIBIT RETURN wire to the other RED wire. If there are no RED wires coming from the service box, contact your equipment supplier or Hamilton Mfg. before proceeding.

- If the externally supplied signal is 24VAC, 24VDC, 12VAC or 12VDC, the CYCLE/INHIBIT pair should be connected directly to the terminal block of the Relay Panel. The proper connection will have one wire of this pair connected to terminal 9 of the Relay Panel (it doesn't matter which one) and the other wire of the pair connected to terminal 10. If there are RED wires coming from the service box connected to the Relay Panel, contact your equipment supplier or Hamilton Mfg. before proceeding.

❑ ADDITIONAL WIRE TERMINATIONS FOR USE WITH THE CRC CREDIT CARD SYSTEM.

The installation of the changer should proceed as outlined in the above section. However, If a CRC Credit Card System is being used, the following must be performed, as well.

- The telephone line used for the changer must be a dedicated line. No other telephones or equipment can be connected with the same line. (The use of line splitters is not permitted.) If more than one CRC changer is to be installed at the same location, a dedicated phone line must be run to each machine.
- The telephone line should be run in a separate conduit. If any other wiring is run in the same conduit, communication problems could occur.
- For more detailed information on installing the CRC, refer to the CRC manual.

3. SETTING THE CAR WASH CYCLE SYNCHRONIZATION SWITCH

The Car Wash Cycle Synchronization Switch is the silver toggle switch located on the Relay Panel (Refer to Figure 3). The proper setting of this switch depends on the equipment used in your car wash system. If the car wash equipment normally leaves the CYCLE/INHIBIT RELAY de-energized while in stand-by, and then energizes the relay briefly when the customer exits the bay, this switch should be set to PASSIVE. If the reverse occurs, where the car wash equipment normally energizes the CYCLE/INHIBIT RELAY while in stand-by, then de-energizes the relay briefly when the customer exits the bay, the switch should be set to ACTIVE.

4. PROGRAMMING CONTROLLER OPTIONS

To set the PROGRAMMABLE OPTIONS, first refer to the PROGRAMMABLE OPTIONS section of this manual for a description of what features are programmable and an explanation of the different selections. Then, refer to the PROGRAMMING section for in-depth coverage of the actual programming process.

5. GENERAL TEST

After completing all of the steps under MECHANICAL and ELECTRICAL INSTALLATION, the following test can be conducted:

- Be sure to test all facets of the operation, including the bill acceptor and coin acceptors.
- Test for proper wash actuation and Cycle/Inhibit control.
- Ensure that coins are being dispensed for both change and as a refund. If there are any problems refer to the TROUBLESHOOTING section or contact Hamilton Mfg.

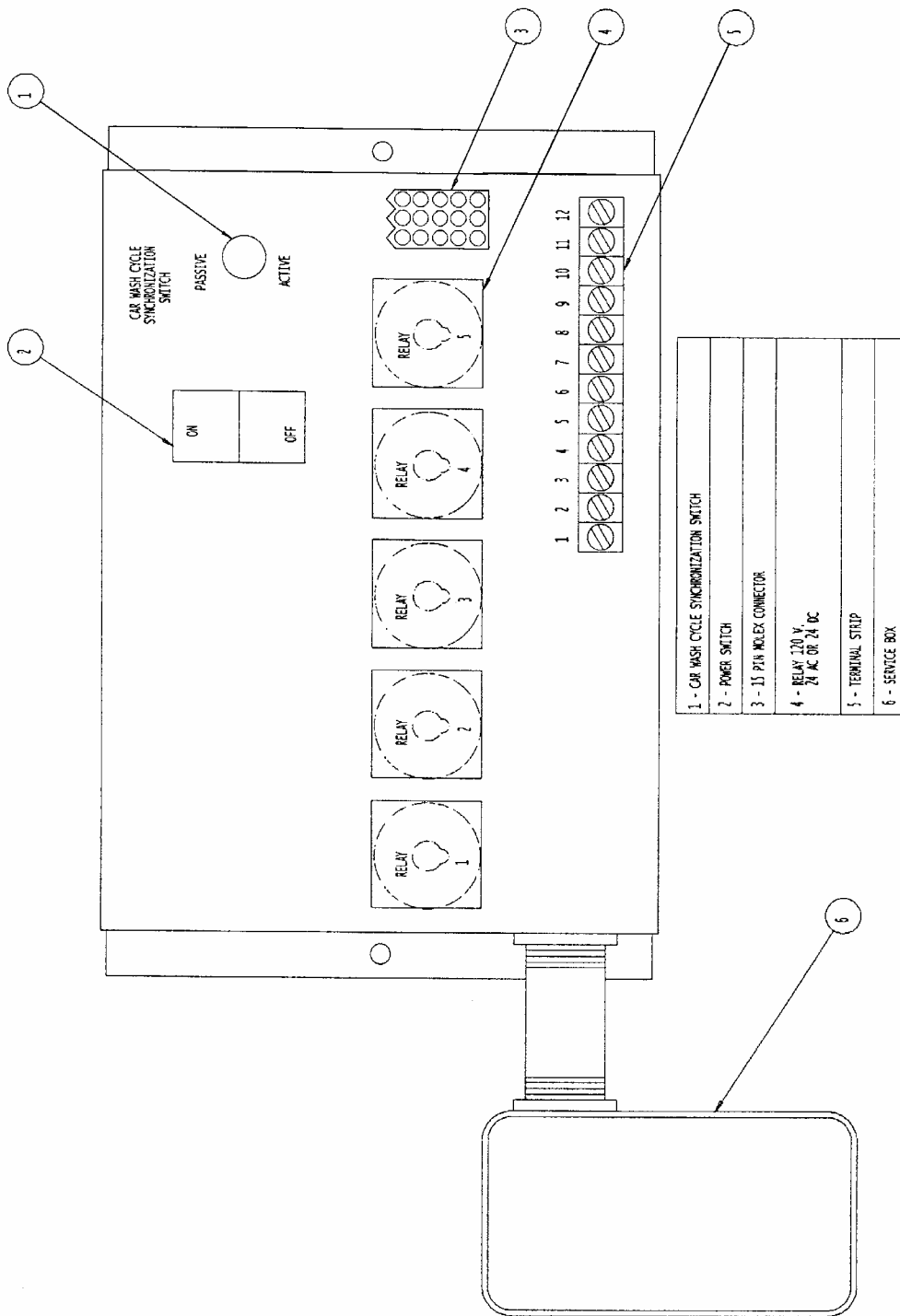

Figure 3
RELAY PANEL

C. MAINTENANCE

A few simple maintenance routines can extend the usefulness and productivity of the ACW-5.

CAUTION!

DO NOT USE OIL, GREASE OR SOLVENTS ON ANY PART OF THIS UNIT EXCEPT AS CLEARLY SPECIFIED IN THIS MANUAL, THE HOPPER MANUAL, THE VALIDATOR, OR THE STACKER MANUAL.

Monthly Maintenance

1. HOPPER

To remove the Hopper from the machine and clean it, follow the steps below:

- Disconnect the **CIRCUIT BREAKER** on the relay panel to turn off all power to the machine.
- Empty all of the coins from the Hopper.
- Unplug the main harness from the bottom of the Hopper.
- Tilt the top of the Hopper backwards slightly, then lift up and forward to remove the Hopper Assembly from the cabinet.
- Use a Phillips screwdriver to remove the eight # 8 x 1/4" self-tapping screws that hold the cover on the outer housing.
- Remove the coin baffle from the outer housing.
- Sweep all debris out of the Hopper with a clean soft brush.
- Dampen a cloth and apply a **HOUSEHOLD CLEANER** to all surfaces inside the coin bowl. Scrub if needed.
- Dampen a clean cloth and soak up any remaining residue.
- Vacuum the inside of the Hopper thoroughly, and return the coins.
- Reassemble the Hopper and re-install it into the machine.

2. VALIDATOR

- Clean the Validator by unplugging and removing it from the cabinet.
- Unscrew the two thumb wheels and open the bottom plate.
- Use a clean soft brush or cloth to remove any lint, dust or dirt that may have become deposited on the sensor lenses, belts and/or wheels.
- Reassemble the Validator and re-install it into the machine.

3. STACKER

The ACW-5 can be operated without the Stacker. If you do not wish to use the Stacker, the BY-PASS PLUG attached to the Stacker Harness must be used. Unplug the Stacker and connect the Harness to the BY-PASS PLUG.

If the Stacker is being used, it is important to perform the following maintenance on a monthly basis:

- Keep the Stacker clean by using a clean soft brush or cloth to remove any lint, dust or dirt.
- Make sure the relay is tight in the socket with the relay bail in place.
- Check operation; the Stacker should cycle smoothly.
- With the Stacker empty, check the pressure plate. Push the plate down and let it go. It should snap freely to the top.

Annual Maintenance

1. VALIDATOR

The Validator should be serviced annually to maintain maximum performance. This work should only be done by a trained technician.

2. STACKER

- All pivot points must be cleaned and re-greased.
- Check the switch tightness and the cam to see if it is still in round.
- Check for bent, loose, worn, rusted or corroded parts.
- Check the motor for coasting.
- Use a small amount of Dry Slick™ on the slides. Do not use grease or WD-40™.

VII. ERROR CODES / TROUBLESHOOTING

The ACW-5 is equipped with a self-diagnostic capability that makes it possible for common problems to be quickly detected and serviced. When most errors occur, the Controller will automatically shut down the entire unit as a precaution in order to prevent further malfunctions. When the ACW-5 shuts itself down after an error has been detected, it de-activates the bill acceptor and coin acceptors so that further deposits cannot be accepted. When this occurs, the display will read:

OUT OF SERVICE

It is necessary to troubleshoot and correct the problem before normal operation can resume. **Shutting off power to the unit will not erase this error condition.**

TO RESUME NORMAL OPERATION, IT IS NECESSARY TO:

1. Acknowledge that you have seen the error. To do this, press the **YELLOW** button on the Controller labeled **ACTION**. When this button is pressed the display will show the detected error. (Possible errors and their descriptions are covered later in this section.)
2. After making note of the error and correcting the problem, it is necessary to once again press the **ACTION** button to return to normal operation. When this button is pressed the display will read:

ERROR ACKNOWLEDGED

briefly, then return to the welcome prompt.

It is possible for the ACW-5 to detect an error and still remain operational. This occurs when the default payment mode has been set to "USE ALT PAYMENT" instead of "OUT OF SERVICE". In the "USE ALT PAYMENT" mode, the Controller will only shut down the component that is malfunctioning. The controller will stop displaying the normal Welcome Messages and instead display the messages "PAYMENT OPTIONS..." and "USE BILLS ONLY" (depending on which payment options are available). When all the payment options have been exhausted, the ACW-5 will shut down and display an error message for the last component malfunction. When this occurs, follow the above steps to return to normal operation.

ERROR CODES

☐ \$5 INPUT STUCK

The normal signal on the \$5 line, in standby, is a TTL level logic high. When signaling that a \$5, \$10 or a \$20 bill has been accepted this line gets pulled low briefly. If this line should get pulled low for an extended period of time, this error will result and the machine will be shut down.

☐ \$1 INPUT STUCK

The normal signal on the \$1 line, in standby, is a TTL level logic high. When signaling that a \$1 bill has been accepted this line gets pulled low briefly. If this line should get pulled low for an extended period of time, this error will result and the machine will be shut down.

25: INPUT STUCK

The normal signal on the Quarter line, in standby, is a TTL level logic high. When signaling that a Quarter has been accepted this line gets pulled low briefly. If this line should get pulled low for an extended period of time, this error will result and the machine will be shut down.

VALIDATOR SHUT DOWN

If the Validator (only an HV-X v3.15 or higher) detects an error it will send a pulse of specific length to the Controller and a special Validator Shut Down error will be displayed. This error indicates a Validator problem, not a Controller problem.

TOKEN INPUT STUCK

The normal signal on the Token line, in standby, is a TTL level logic high. When signaling that a token coin has been accepted this line gets pulled low briefly. If this line should get pulled low for an extended period of time, this error will result and the machine will be shut down.

DROP SWITCH STUCK

The normal signal on the Drop line, in standby, is a TTL level logic low. When signaling that a coin is being dispensed this line gets pulled high briefly. If this line should get pulled high for an extended period of time, this error will result and the machine will be shut down. This situation is only tested during the time a payout is occurring.

UNEXPECTED COIN DROP

The normal signal on the Drop line, in standby, is a TTL level logic low. When a coin is dispensed, this line goes high briefly, then returns to its logic low state. If the Controller records two unexpected coin drop signals while in standby, the machine will shut down with this error.

HOPPER COASTING ERROR

If two coin drop signals are recorded immediately after the Hopper has paid out, the machine will shut down with this error.

HOPPER TIME-OUT

The normal signal on the Drop line, in standby, is a TTL level logic low. When a coin is dispensed, this line goes high briefly then returns to its logic low state. If during the time a payout is occurring a high pulse is not detected for 10 consecutive seconds this error will result and the machine will be shut down.

STACKER TIME-OUT

The normal signal on the Busy line, in standby, is a TTL level logic low. This line goes high during the bill stacking process then returns to its logic low state when the Stacker reaches its home position. If the Stacker never returns to its home position, this error will result and the machine will be shut down.

MULTIPLE POWER INT

There is special circuitry inside the Controller to determine if a power outage has occurred. If there are several power outages while processing money (dispensing coins, stacking bills, etc.) this error will occur and the machine will be shut down.

MEMORY DATA ALTERED!

There are special detection routines built into the Controller's program that can determine if its memory has been corrupted. If the memory is corrupted, values such as wash prices and

the audits can no longer be trusted. If this should occur, the entire memory is cleared and the machine will be shut down. Re-programming the Controller will be necessary since all settings will default to the lowest possible denomination (\$0.00) for credits and the highest possible denomination (\$63.75) for any payment option. This default mechanism is used as a safeguard to ensure that the machine does not give away free washes. Below is a list of the PROGRAMMABLE OPTIONS and their default settings.

PROGRAMMABLE OPTIONS	DEFAULT SETTINGS
TOKEN COIN MODE?	MULTIPLE CREDITS
TOKEN COIN VALUE?	\$0.00
TOKENOTE® MODE?	MULTIPLE CREDITS
TOKENOTE® VALUE?	\$0.00
COUPON DISCOUNTS?	\$0.00
ITEM PRICES?	\$63.75
ITEM NAMES?	BLANK
PROCEED PROMPTS?	BLANK
WELCOME PROMPTS?	BLANK
SET DATE & TIME?	SUN 01-01-00 12:00 A
VEND DURATION?	1.0 SECOND
SET EMPTY MODE?	OUT OF SERVICE
SET BUILD MODE?	LIMIT DISABLED
SET PAY DEFAULT?	OUT OF SERVICE
SET HOPPER STYLE?	NEW STYLE HOPPER
SET DISPLAY STYLE?	REGULAR (20 CHAR)
SET BUTTON ENABLE?	ENABLED

★ The following errors will be displayed as long as the faulty condition exists, but will be cleared as soon as the condition is corrected. **THIS MEANS THESE ERRORS DO NOT NEED TO BE ACKNOWLEDGED BY PRESSING THE ACTION BUTTON.**

HOPPER EMPTY

The normal signal on the Empty line, in standby, is a TTL level logic low. When there are not enough coins to make a connection from the bottom of the Hopper up to the two coin sensing plates in the Hopper bowl, this line goes high. When this happens, the Hopper Empty error will result. Refilling the Hopper with coins will automatically clear this error.

RELEASE BUTTON

When one of the item selection buttons is held in for an extended period of time this message will appear on the display. Releasing the button should automatically clear this error. If the error does not clear, however, it could indicate a broken or stuck REFUND button or contact block. Dislodge or replace the button or contact block to remedy this error. If the error still does not clear, there may be damage to the CPU, in which case you should contact the factory for assistance.

--PLEASE WAIT!--CAR WASH BUSY--

The normal signal at the Controllers cycle input is a TTL level logic low. When the car wash signals that a customer is leaving the bay, this line goes to a high logic level for the duration of the signal from the car wash. If this line should unexpectedly go high (no car should be in

the wash) for more than 8 seconds, this error will occur indicating a malfunction in the car wash system. Returning the cycle line to its normal state will automatically clear this error.

Another cause for this error may be that the blue connector on the split harness has come loose or undone. Be sure to check this connection. If it is loose, reconnect it to clear the error.

☐ --OUT OF SERVICE---CAR WASH CLOSED---

The normal signal at the Controllers cycle input is a TTL level logic low. When the car wash signals that a customer is leaving the bay, this line goes to a high logic level for the duration of the signal from the car wash. If this line should unexpectedly go high (no car should be in the wash) for more than 10 minutes, this error will occur indicating a malfunction in the car wash system. Returning the cycle line to its normal state will automatically clear this error.

TROUBLESHOOTING

In addition to the self-diagnostic error codes, there are other possibilities that could arise in the installation or at some point during the extended operation of your ACW-5. This section provides a general troubleshooting guide, broken down into categories of symptoms.

TROUBLESHOOTING GUIDE		
DISPLAY QUESTIONS		
SITUATION	PROBABLE CAUSE	CORRECTIONS
<ul style="list-style-type: none"> • Display is blank • No manual Hopper run • No functions • No LED on Validator 	<ul style="list-style-type: none"> A. No power source B. Circuit Breaker is set to off 	<ul style="list-style-type: none"> A. Switch on main power B. Switch on Circuit Breaker
<ul style="list-style-type: none"> • Display is always blank • Hopper runs using manual switch located on bottom rear of Hopper 	Controller display problems	Contact the factory for assistance
Display is blank until button is pushed or credit is deposited	Welcome Messages are not programmed	Program Welcome messages
Display reads "OUT OF SERVICE" alternating to "HOPPER EMPTY", or display reads "USE EXACT AMOUNT" alternating to "NO CHANGE RETURNED"	<ul style="list-style-type: none"> A. Coin Hopper is empty B. Sensors are dirty C. Loose connection on Empty Circuit 	<ul style="list-style-type: none"> A. Refill Hopper B. Clean Sensors (See INSTALLATION / MAINTENANCE section) C. Locate and repair the connection
Display reads "OUT OF SERVICE"	Error detected by Controller (See Error Codes)	Correct malfunction, acknowledge error
Display reads "RELEASE BUTTON"	<ul style="list-style-type: none"> A. Refund Button or contact block is stuck B. Damage to CPU 	<ul style="list-style-type: none"> A. Dislodge stuck button or contact block B. Contact the factory for assistance

TROUBLESHOOTING GUIDE

MONEY ACCEPTANCE QUESTIONS

SITUATION	PROBABLE CAUSE	CORRECTIONS
<ul style="list-style-type: none"> • Cannot activate refund • Credit is showing on display 	<ul style="list-style-type: none"> A. In "USE EXACT AMOUNT" mode B. Contact buttons are not working C. CPU input is missing 	<ul style="list-style-type: none"> A. Fill coin Hopper or change mode to "OUT OF SERVICE" B. Replace contact block C. Contact the factory for assistance
<ul style="list-style-type: none"> • Accepts fee, but car wash does not start • "DRIVE AHEAD" or similar message shown on ACW Display 	Observe the VEND RELAYS and see below	Observe the VEND RELAYS and see below
IF THE RELAY ACTIVATES...	<ul style="list-style-type: none"> A. Duration of relay closure is too long or too short for wash equipment to recognize B. Wash equipment is not accepting signal from ACW C. Broken connection in wiring between ACW and wash equipment 	<ul style="list-style-type: none"> A. Reprogram "VEND DURATION" setting in ACW Controller B. Refer to the car wash manual C. Locate and repair connection
IF RELAY DOES NOT ACTIVATE...	<ul style="list-style-type: none"> A. Vend relay is loose or defective B. Broken connection in wiring between ACW Controller and relay panel C. Output missing from Controller 	<ul style="list-style-type: none"> A. Reinstall or replace relay B. Locate and repair connection C. Contact the factory for assistance
One Coin Acceptor does not accept coins	<ul style="list-style-type: none"> A. Broken connection on power wires to Coin Acceptor B. Coin Acceptor sensitivity is too high C. Coin Acceptor is defective 	<ul style="list-style-type: none"> A. Locate and repair connection B. Adjust sensitivity C. Replace Coin Acceptor

TROUBLESHOOTING GUIDE

MONEY ACCEPTANCE QUESTIONS (CONT...)

SITUATION	PROBABLE CAUSE	CORRECTIONS
<ul style="list-style-type: none"> ● Both Coin Acceptors do not accept coins ● Validator does accept bills 	<ul style="list-style-type: none"> A. Broken connection on either the power wires supplying the Transformer, or the wires from the Transformer to the Coin Acceptor B. Transformer not working C. Both Coin Acceptors are defective 	<ul style="list-style-type: none"> A. Locate and repair connection B. Replace Transformer C. Replace Coin Acceptors
<ul style="list-style-type: none"> ● Both Coin Acceptors do not accept coins ● Validator is disabled 	<ul style="list-style-type: none"> A. Controller is either OUT OF SERVICE, in PROGRAMMING MODE or TRANSMITTING DATA B. Broken connection on ENABLE wire which runs from the Controller to the Validator and Transformer C. ENABLE output missing from Controller 	<ul style="list-style-type: none"> A. Place Controller in RUN MODE B. Locate and repair connection C. Contact the factory for assistance
Coin Acceptor accepts only some coins	<ul style="list-style-type: none"> A. Coins being used are of poor quality B. Coin Acceptor sensitivity too high C. Loose connection to Coin Acceptor 	<ul style="list-style-type: none"> A. Use a different coin sample B. Adjust sensitivity C. Locate and repair connection
<ul style="list-style-type: none"> ● Validator disabled (Validator LED flashing only half of "1") ● Coin Acceptor is working 	<ul style="list-style-type: none"> A. Broken connection on ENABLE wire from Controller to Validator B. Validator ENABLE circuit changed 	<ul style="list-style-type: none"> A. Locate and repair connection B. Contact the factory for assistance
<ul style="list-style-type: none"> ● Validator dead (No LED lit on Validator) ● Coin Acceptor is working 	<ul style="list-style-type: none"> A. Broken connection on power wires to Validator B. Validator is defective 	<ul style="list-style-type: none"> A. Locate and repair connection B. Contact the factory for assistance

TROUBLESHOOTING GUIDE

MONEY ACCEPTANCE QUESTIONS (CONT...)

SITUATION	PROBABLE CAUSE	CORRECTIONS
<ul style="list-style-type: none"> • Validator dead (LED lit, but not displaying error code) • Coin Acceptor is working 	<ul style="list-style-type: none"> A. Dirty or blocked sensor inside Validator B. Blocked bill path (will not allow insertion) C. Validator drive train problems D. Validator PCB damaged 	<ul style="list-style-type: none"> A. Remove obstruction or clean sensors B. Remove obstruction C. Contact the factory for assistance D. Contact the factory for assistance
Validator dead (LED flashing error code)	Error detected by Validator PCB	Refer to the Validator Manual for Validator error codes
Validator runs without inserting a bill	Dirty blocked sensor inside Validator	Remove obstruction or clean sensors
Validator rejects too many bills or all bills (bill goes in and comes back out)	<ul style="list-style-type: none"> A. Dirty sensor, magnetic heads or rollers B. Validator requires service 	<ul style="list-style-type: none"> A. Clean as needed or contact the factory for assistance B. Contact the factory for assistance
<ul style="list-style-type: none"> • Validator accepts bills • Does not give credit 	<ul style="list-style-type: none"> A. Bill stuck completely or partially in Validator B. Error detected C. Broken connection on vend wires between Validator and Controller D. Controller CPU missing input 	<ul style="list-style-type: none"> A. Determine cause of sticking and remove bill from Validator (Refer to the Validator Manual), or Contact the factory for assistance B. Refer to the Validator Manual or contact the factory for assistance C. Locate and repair connection D. Contact the factory for assistance

TROUBLESHOOTING GUIDE

HOPPER QUESTIONS

SITUATION	PROBABLE CAUSE	CORRECTION
Overpayment of change	<ul style="list-style-type: none"> A. Wash prices set incorrectly B. Hopper not counting coins 	<ul style="list-style-type: none"> A. Check wash prices B. Perform HOPPER PAYOUT TEST (Refer to the Hopper Manual), or contact the factory for assistance
<ul style="list-style-type: none"> • Hopper does not run • Hopper does not pay back change 	<ul style="list-style-type: none"> A. Coin or foreign material lodged in Hopper B. Broken connection in wire between Controller and Hopper motor C. Output missing from Controller 	<ul style="list-style-type: none"> A. Clear obstruction in Hopper B. Locate and repair connection C. Contact the factory for assistance
Hopper runs slowly	<ul style="list-style-type: none"> A. Foreign material in Hopper B. Output weak from Controller 	<ul style="list-style-type: none"> A. Remove foreign material B. Contact the factory for assistance
<ul style="list-style-type: none"> • Underpayment of change • Controller does not go into "OUT OF SERVICE" 	<ul style="list-style-type: none"> A. Wash prices set incorrectly B. Coins fall back into Hopper after counting C. CPU misreads coin count 	<ul style="list-style-type: none"> A. Check wash prices B. Perform HOPPER PAYOUT TEST (Refer to the Hopper Manual), or contact the factory for assistance C. Contact the factory for assistance
<ul style="list-style-type: none"> • Underpayment of change • Controller does go into "OUT OF SERVICE" 	Error detected by Controller (See ERROR CODES)	Correct malfunction, acknowledge error

VIII. RETURNING ITEMS FOR SERVICE

If any part or component must be shipped to the distributor or the manufacturer for replacement or repair, the following procedure is used:

- **CALL BEFORE SHIPPING. BE READY WITH THE MACHINE SERIAL NUMBER AND THE COMPONENT SERIAL NUMBER. YOU WILL RECEIVE A RETURN AUTHORIZATION NUMBER (RA NUMBER). WRITE THE RA NUMBER ON THE OUTSIDE OF THE BOX YOU ARE USING TO RETURN THE COMPONENT, AS WELL AS ON AN ENCLOSED NOTE.**
- If shipping components, first place in a plastic bag before putting in a box and surrounding with good packing material.
- Ship via **UNITED PARCEL SERVICE (UPS)** if at all possible.
- If shipped by **U.S. POSTAL SERVICE (Parcel Post)**, send by **SPECIAL HANDLING**.
- Adequately insure shipments; if uncertain about the value, call the distributor or the manufacturer for information.
- **Include a note in shipment describing the nature of the problem, along with a full return address. WE CANNOT RETURN SHIPMENTS TO POST OFFICE BOXES. Be sure to include the RA Number.**
- Please include your **NAME** and a **TELEPHONE NUMBER** where you can be reached.

IX. PARTS

The following is a list of parts for the ACW-5, which may be ordered from your Hamilton Distributor or direct from the factory. When calling to place a part order, make sure you have the changer model and serial number available.

PART NO.	PART DESCRIPTION	QTY
11-0033	HOPPER PIVOT BRACKET	1
11-0101	HOPPER ASSEMBLY, HSH-A	1
36-0036	SINGLE STACKER	1
46-0170R	HV-X VALIDATOR WITH CHUTE (Specify Serial Number)	1
46-7000A	COIN MECH TRANSFORMER ASSEMBLY	1
47-0024	PAYOUT RELAY	*5
	or	
47-0202	PAYOUT RELAY, 24VAC	*1
	or	
47-0203	PAYOUT RELAY, 24VDC	*1
	or	
47-0205	PAYOUT RELAY, 12VAC	*1
	or	
47-0206	PAYOUT RELAY, 12VDC	*1
47-0049	CONTACT BLOCK	5
47-0050	SWITCH BUTTON , ACW RED	4
47-0077	CHANGER GROUND TERMINAL	3
47-0084	SWITCH BUTTON, ACW BLACK or BLUE	1
47-0155A	OUT OF SERVICE RELAY KIT (Optional)	1
47-0232	CLAMP, CABLE PANDUIT	14
47-0275	CABLE TIE 6"	**17
47-2021A	SEIKO PRINTER (Optional)	1
48-0006A	HEATER ASSEMBLY	1
48-0033A	STACKER BYPASS PLUG	1
48-1000	COIN MECH HARNESS, ACW "Y"	1
48-1011	HARNESS, AC/DC SPLIT	1
48-2000A	ACW PRINTER HARNESS (Optional)	1

PART NO.	PART DESCRIPTION	QTY
49-0560A	CRC COMMUNICATION CONTROLLER (For use with the ACW-5-CRC) (Specify Model and Serial Number)	1
49-0562A	ACW BEEPER ASSEMBLY	1
49-1020	SHIELD, ACW PAN	1
49-1029C	ACW-5 RELAY PAN & OUTLET ASSEMBLY, COMPLETE (For use with the ACW-5)	1
49-1029E	ACW-4-CC RELAY PAN & OUTLET ASSEMBLY, COMPLETE (For use with the ACW-5-CRC)	1
49-1200B	CONTROLLER COMPLETE, ACW (Specify Model and Serial Number)	1
49-2010A	AUDIT PRO REMOTE w/CABLE (For use with the ACW-5-CRC)	1
49-2016A	CARD READER ASSEMBLY (For use with the ACW-5-CRC)	1
60-0282	HV-X SLIDER FACEPLATE	1
60-0284	HV-X CLAMPING FACEPLATE	1
60-0064	COIN ENTRANCE CHUTE, .25	2
60-0011	TOKEN BOX, ACW	1
60-0014	COIN SLOT, .25	1
60-0115	VALIDATOR BRACKET, NS	1
60-0116	VALIDATOR SUPPORT BRACKET	1
60-0040	COIN SLOT, 1-1/8" TOKEN	1
60-0205	CHUTE, ACW COIN	1
60-0206	CHUTE, ACW COIN RETURN	1
60-0207	BRACKET, ACW STACKER	1
60-0240A	ACW-4 FAN ENCLOSURE ASSEMBLY	1
60-0241	ENCLOSURE, ACW CONTROLLER	1
60-0242	BRACKET, VALIDATOR SEAL CLAMPING	1
60-0243	SEAL, VALIDATOR WATER	1
60-0245A	ACW ENVIRO ENCLOSURE KIT	1
60-0249	COIN MECH BRACKET & CHANNEL ASSEMBLY	2
61-0581A	26" STAINLESS STEEL BASE (Optional)	1
61-0582A	20" PEDESTAL BASE (Optional)	1
61-0589A	26" PEDESTAL BASE (Optional)	1
61-0592A	20" STAINLESS STEEL BASE (Optional)	1
61-0590A	ACW ENCLOSURE (Optional)	1
61-0590C	ACW ENCLOSURE w/EXTERNAL DISPLAY (Optional)	1

PART NO.	PART DESCRIPTION	QTY
61-0594A	EXTERNAL DISPLAY (Optional)	1
61-0615A	ACW-5 CABINET COMPLETE	1
	or	
61-0615C	ACW-5-CRC CABINET COMPLETE	1
63-0420A	FACE PANEL ASSEMBLY, ACW-5 (Specify Model and Serial Number)	1
63-5005	LOCK INSERT, 1 PAIR	1
63-5006	LOCK BARRELS	2
80-0008	COIN ACCEPTOR	2
80-0051A	COIN MECH ASSEMBLY, ACW-4	1
90-0026	SCREW, 4-40 x 1/2" PH	3
90-0129	SCREW, 6-32 x 3/8" PH	2
90-0131	SCREW, 6-32 x 3/16" PH	8
90-0142	SCREW, 8-32 x 1/4"	4
90-0250	MOUNTING STUD CONTROLLER, LONG	4
90-0275	LOCK BOLT	2
90-0301	NUT, 10-24 x 3/8"	2
90-0310	NUT, 6-32 x 5/16" HEX	2
90-0326	NUT, 10-24 LOCK	4
90-0331	NUT, 1/4-20" x 1/2"	4
90-0336	LOCK NUT, SPRING LOADED	2
90-0403	INTERNAL LOCKWASHER, 1/4"	4
90-0428	WASHER, SPACER	6
90-0429	WASHER, 1/4 x 3/4"	4
90-0514	SCREW, 10-32 x 5/16" PH	2
90-0611	INTERNAL LOCKWASHER, #8	3
90-0612	INTERNAL LOCKWASHER, #10	5
90-0661	SET SCREW, 10-24 X 3/8"	1
96-0157A	ASSEMBLY DECAL, ACW-4	1

* The following combinations of PAYOUT RELAYS can be used:

- 5 of part number 47-0024, or
- 4 of part number 47-0024 and 1 of part number 47-0202 (24VAC), or
- 4 of part number 47-0024 and 1 of part number 47-0203 (24VDC), or
- 4 of part number 47-0024 and 1 of part number 47-0205 (12VAC), or
- 4 of part number 47-0024 and 1 of part number 47-0206 (12VDC)

** Add an additional 11 Cable Ties for an ACW-5-CRC.

APPENDIX B

ACW-4 SPLIT HARNESS

(LEFT SIDE)

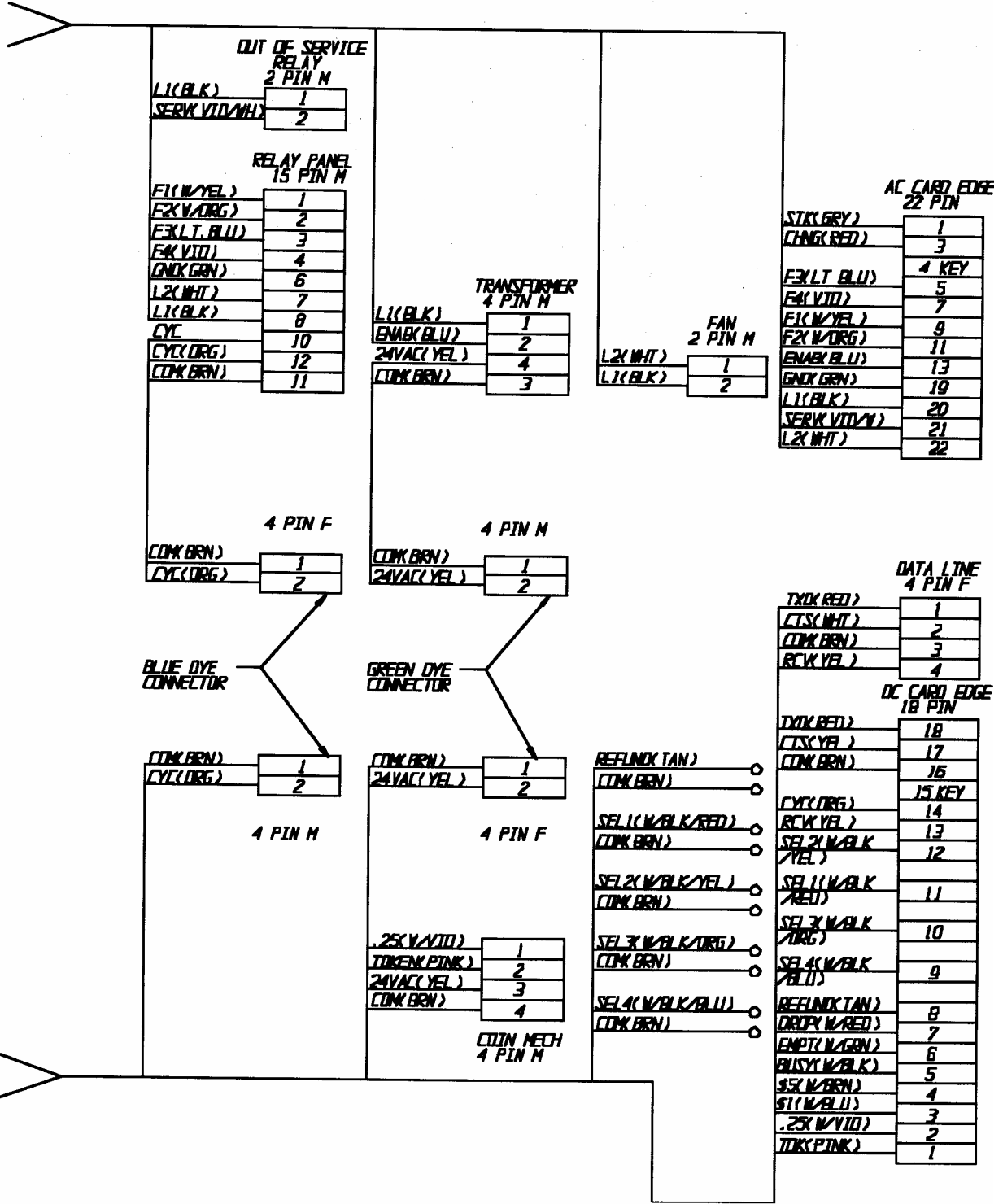

ACW-4 SPLIT HARNESS (Right Side)

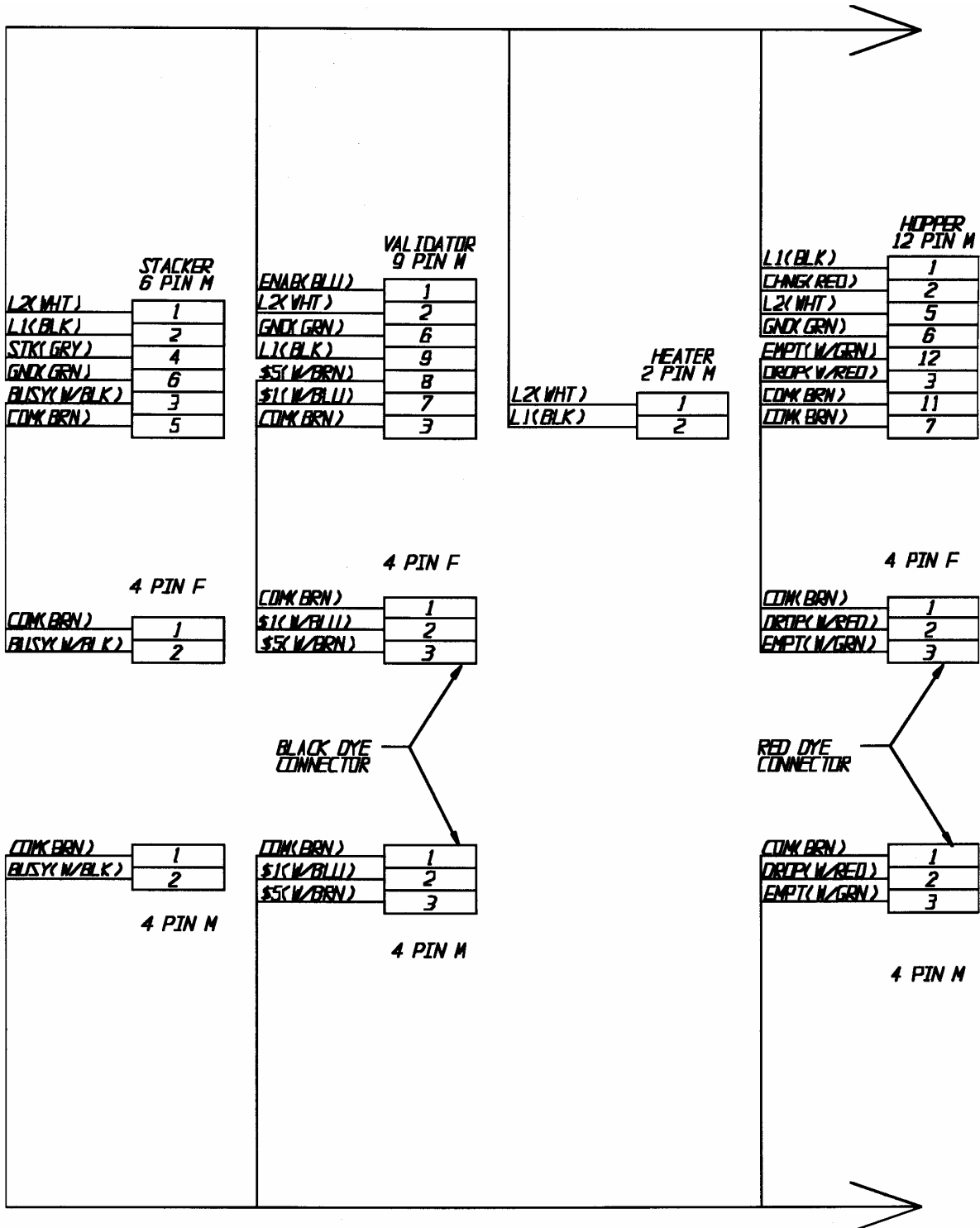

SPLIT HARNESS LEGEND

SYMBOL	FUNCTION
\$.25	The Coin Mech sends a signal to the Controller indicating a coin or token is accepted (normally open connection to logic ground)
\$1	The Validator sends a signal to the Controller for \$1 (normally open connection to the logic ground)
\$5	The Validator sends a signal to the Controller, using different pulses for 5, 10 or 20 dollar bills (normally open connection to the logic ground)
24VAC	24 Volt Alternating Current to power the Coin Acceptors
BUSY	Signal from the Stacker to the Controller that indicates the Stacker is not in standby position (normally closed connection to the logic ground)
CHNG	Powers the Hopper during coin payout, 120VAC Neutral
COM	Common (logic ground connection used in all components)
CTS	Clear To Send, from printer to Controller
CYC	A signal that indicates a car has exited. The Signal comes from the car wash or parking gate to toggle the Cycle Relay (normally closed connection to logic ground within the Cycle Relay)
DROP	Sends a signal to the Controller that indicates a coin payout (normally closed connection to the logic ground)
EMPT	A circuit opens when the Hopper is near empty, sending a signal to the Controller (normally closed connection to the logic ground)
ENAB	Allows Validator to take bills, 120VAC Neutral signal comes from the Controller
F1	Relay 1 activation ,120VAC Neutral signal comes from the Controller to the Relay Pan
F2	Relay 2 activation, 120VAC Neutral signal comes from the Controller to the Relay Pan
F3	Relay 3 activation , 120VAC Neutral signal comes from the Controller to the Relay Pan
F4	Relay 4 activation , 120VAC Neutral signal comes from the Controller to the Relay Pan
GND	Earth Ground
L1	120VAC Hot
L2	120VAC Neutral
RCV	Signal from the computer to the Controller in a credit card system, indicates if card is approved or denied
REFUND	An open circuit that sends a signal to the Controller when the selection is pushed (normally open connection to logic ground)
SEL1	An open circuit that sends a signal to the Controller when the selection is pushed (normally open connection to logic ground)

SPLIT HARNESS LEGEND (cont...)

SYMBOL	FUNCTION
SEL2	An open circuit that sends a signal to the Controller when the selection is pushed (normally open connection to logic ground)
SEL3	An open circuit that sends a signal to the Controller when the selection is pushed (normally open connection to logic ground)
SEL4	An open circuit that sends a signal to the Controller when the selection is pushed (normally open connection to logic ground)
SERV	OUT OF SERVICE light activation. This line is a switched 110VAC Neutral line
STK	Triggers the Stacker to run. A momentary 120VAC Neutral signal comes from the Controller
TOK	Coin Mech sends a signal to the Controller indicating a coin or token is accepted (normally open connection to logic ground)
TXD	Serial Data Out , from Controller to printer

APPENDIX C

TOKENOTE® TRAINING GUIDE FOR AUTO CASHIERS

A Tokenote® is a paper coupon that can be accepted by the Validator. It is intended to give credit towards the wash price and not as a substitute for cash. Because of this, change will not be dispensed if the value of a Tokenote® exceeds the wash price. Likewise, the value of a Tokenote® cannot be refunded in cash.

When programming your machine to accept Tokenotes®, refer to the options listed below to help you decide which programming method to use.

- To program one or more Tokenotes® with the same value, refer to SECTION A.**
- To program two or more Tokenotes® with different values, refer to SECTION B.**
- To Program Token Coins, refer to SECTION C.**
- To Void Tokenotes, refer to SECTION D.**

Sections A-D can be found on the following pages.

Refer to the PROGRAMMABLE OPTIONS section and the PROGRAMMING section for additional information.

A. PROGRAMMING ONE OR MORE TOKENOTES® WITH THE SAME VALUE

☐ MATERIALS NEEDED:

- **VALIDATOR** - A Hamilton HVX Validator.
- **TOKENOTE®** - A uniquely coded paper coupon that can be accepted by the Validator and used as credit towards a wash. These must be specially ordered from Hamilton Mfg. or your Hamilton Distributor.
- **CLEAR ALL COUPON** – The CLEAR ALL Coupon is used to erase all previously trained Tokenotes® so that the Validator will no longer accept any of those Tokenotes®.

★ It is important that all Tokenotes® and Coupons are intended for the type of Validator being used. For example, Tokenotes® and Coupons intended for an HV7-T will not work in an HVX. When ordering new Tokenotes® and Coupons, please specify the Validator type.

★ It is also important to realize that accepted Tokenotes® will issue a programmable amount of credit good towards all wash selections. Tokenote® use cannot be limited to a specific wash or subset of washes.

☐ TO PROGRAM, FOLLOW THE STEPS BELOW:

VALIDATOR

1. With the power on, check the operation of the changer. A dot flashing on the LED indicates the machine is operating normally.
2. Note the position of each switch on the DIP switch. (The DIP switch is located on the side of the Validator.)
3. Set all 10 DIP switches to the OFF position. Then, starting with Switch #10, slowly move the switches to the ON position, one switch at a time and in decreasing order (10, 9, 8, 7...). The LED should now be flashing the letter "P". This signifies that the Validator is in the Tokenote® Programming Mode.
4. At this point, it is recommended to insert the CLEAR ALL Training Coupon, especially if this the first time the Validator is being programmed or if it has just been returned after being service. The CLEAR ALL Coupon will erase all previously trained Tokenotes® from the Validator's memory but will not affect the Controller's memory.
5. Insert one Tokenote® into the Validator, making sure that it is accepted.
6. Repeat Step 5 for each uniquely coded Tokenote® you wish to program. (Make sure that each Tokenote® is equal in value.) Up to 16 different codes can be programmed.
7. Starting with Switch #1, slowly move the switches back to their original positions one at a time. This must be done in increasing order (1, 2, 3, 4...). A dot should now be flashing on the LED. (If using an HVX Validator, Switch #2 must be in the OFF position in order to accept Tokenotes®.)

CONTROLLER

1. Press the ACTION (YELLOW) button on the side of the Controller to enter the MENU MODE.
2. Use the RED and BLUE (or BLACK) buttons to scroll through the categories until "TOKENOTE® VALUE?" is displayed.
3. Press the ACTION button to enter the PROGRAMMING MODE.
4. Use the RED and BLUE (or BLACK) buttons to increase or decrease the value in \$0.25 increments.
5. When the desired value is displayed, press the RETURN (WHITE) button twice to return to the RUN MODE.

B. PROGRAMMING TWO OR MORE TOKENOTES® WITH DIFFERENT VALUES

☐ MATERIALS NEEDED:

- **VALIDATOR** - A Hamilton HVX Validator.
- **TOKENOTE®** - A uniquely coded paper coupon that can be accepted by the Validator and used as credit towards a wash. These must be specially ordered from the manufacturer or your Hamilton Distributor.
- **TRAINING COUPONS** – Training Coupons are used to program Tokenotes® into the Validator’s memory. There are four different Training Coupons: Coupon #1, Coupon #2, Coupon #3, and Coupon #4.
- **CLEAR ALL COUPON** – The CLEAR ALL Coupon is used to erase all previously trained Tokenotes® so that the Validator will no longer accept any of those Tokenotes®.

★ It is important that all Tokenotes® and Coupons are intended for the type of Validator being used. For example, Tokenotes® and Coupons intended for an HV7-T will not work in an HVX. When ordering new Tokenotes® and Coupons, please specify the Validator type.

☐ TO PROGRAM, FOLLOW THE STEPS BELOW:

VALIDATOR

1. With the power on, check the operation of the changer. A dot flashing on the LED indicates the machine is operating normally.
2. Note the position of each switch on the DIP switch. (The DIP switch is located on the side of the Validator.)
3. Set all 10 DIP switches to the OFF position. Then, starting with Switch #10, slowly move the switches to the ON position, one switch at a time and in decreasing order (10, 9, 8, 7...). The LED should now be flashing the letter “P”. This signifies that the Validator is in the Tokenote® Programming Mode.
4. At this point, it is recommended to insert the CLEAR ALL Training Coupon, especially if this is the first time the Validator is being programmed or if it has just been returned after being service. The CLEAR ALL Coupon will erase all previously trained Tokenotes® from the Validator’s memory but will not affect the Controller’s memory.
5. Insert one Tokenote® into the Validator, making sure that it is accepted.
6. Insert Training Coupon #1 into the Validator, making sure that it is accepted.
7. Repeat Steps 5 and 6 to program each uniquely coded Tokenote® of the same value.

8. To program a differently coded Tokenote® with a different value, simply insert that Tokenote® into the Validator, followed by Coupon #2. Repeat as needed, using Coupons #3 and #4 for each Tokenote coded differently. Altogether, up to 16 different codes can be programmed.
9. Starting with Switch #1, slowly move the switches back to their original positions one at a time. This must be done in increasing order (1, 2, 3, 4...). A dot should now be flashing on the LED. **(If using an HVX Validator, Switch #2 must be in the OFF position in order to accept Tokenotes®.)**

CONTROLLER

1. Press the ACTION (YELLOW) button on the side of the Controller to enter the MENU MODE.
2. Use the RED and BLUE (or BLACK) button to scroll through the categories until "COUPON DISCOUNTS" is displayed.
3. Press the ACTION button to enter the PROGRAMMING MODE. "COUPON #1" will be displayed.
4. Use the RED and BLUE (or BLACK) buttons to scroll through the values until the desired amount is displayed.
5. To program the next coupon, use the ACTION button to scroll through the four coupons, and the RED and BLUE (or BLACK) buttons to raise or lower the values.
6. Press the RETURN (WHITE) button twice to return to the RUN MODE.

☐ WHEN PROGRAMMING MORE THAN ONE TOKENOTE®, IT IS IMPORTANT TO KEEP THE FOLLOWING IN MIND:

- Tokenotes® may be programmed into the four COUPON DISCOUNTS categories (using Training Coupons #1 – 4) and the TOKENOTE® VALUE? category all at the same time. Tokenotes® may be distributed evenly throughout these categories, or spread out using any combination, as long as the Tokenote® values are the same for each category. When programming, always start the first Tokenote® in the TOKENOTE® VALUE? category. Use the COUPON DISCOUNTS categories when using multiple values.
- The same Tokenote® code cannot be programmed into different categories.
- Up to 16 differently coded Tokenotes® can be programmed at one time. (The Validator can learn up to 16 different codes.)
- It is possible to use one coupon to program several differently coded Tokenotes®, as long as they are of equal value. (For example, Coupon #1 can be used to program 3 differently coded Tokenotes® with a value of \$5 each.)

TRAINING TOKENOTES® ON THE VALIDATOR

STARTING WITH SWITCH #10, SET SWITCHES TO "ON" POSITION IN DECREASING ORDER (10, 9, 8, 7...). A "P" WILL BEGIN FLASHING ON THE LED

NOTE: If using more than one Tokenote®, coded differently but of equal value, insert one right after the other. Make sure that each Tokenote® is accepted by the Validator.

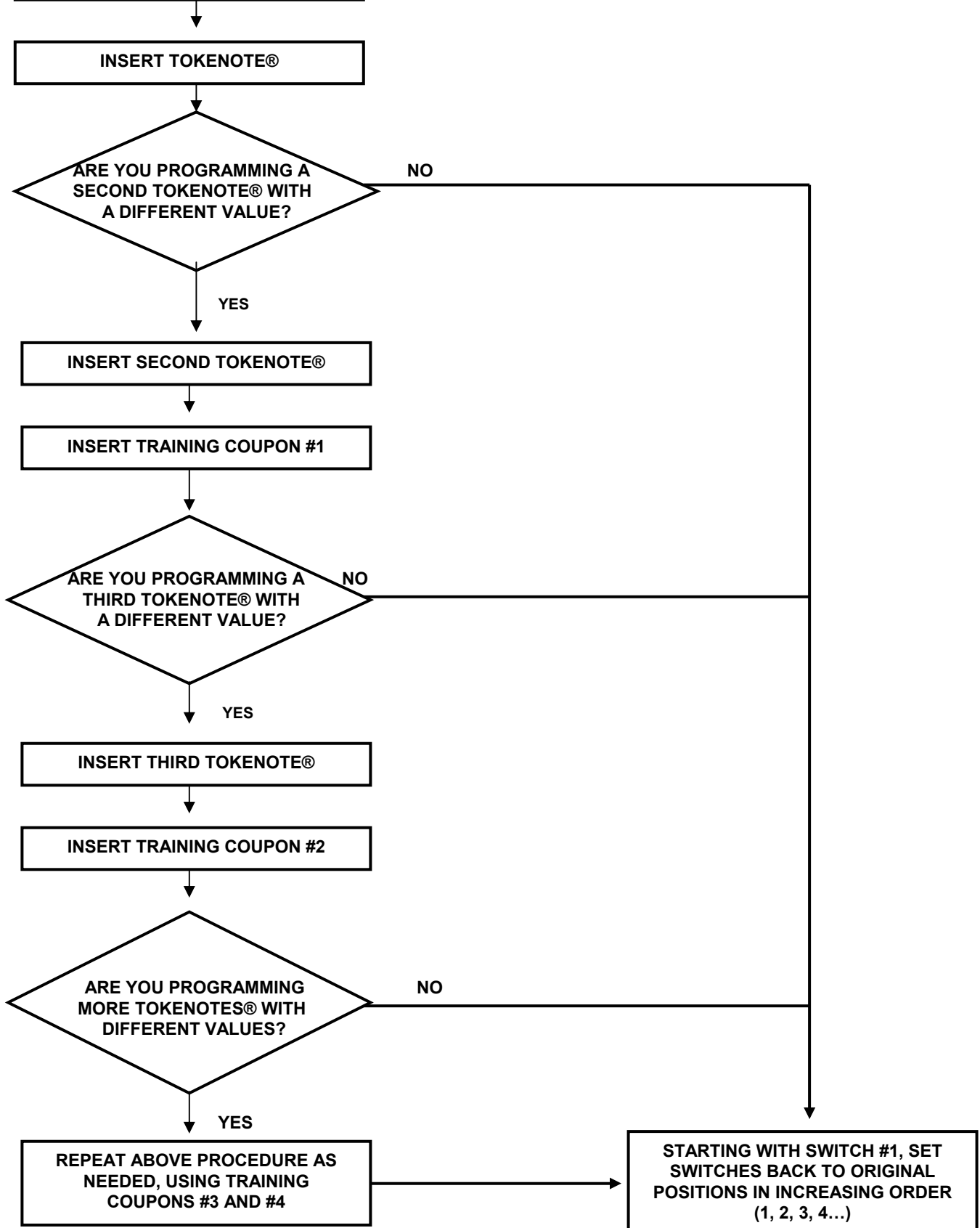

C. PROGRAMMING TOKEN COINS

☐ MATERIALS NEEDED

- **COIN ACCEPTOR**
- **TOKEN COINS** – For information on where to purchase Token Coins, check with your distributor, or contact Hamilton for a distributor in your area.

☐ TO PROGRAM, FOLLOW THE STEPS BELOW:

COIN ACCEPTOR

1. With the power on, check the operation of the changer. A dot flashing on the Validator LED indicates the machine is operating normally.
2. Insert a sample token into the coin acceptor.
3. Insert a second token to verify acceptance.

CONTROLLER

1. Press the ACTION (YELLOW) button on the side of the Controller to enter the MENU MODE.
2. Use the RED and BLUE (or BLACK) button to scroll through the categories until “TOKEN COIN VALUE?” is displayed.
3. Press the ACTION button to enter the PROGRAMMING MODE.
4. Use the RED and BLUE (or BLACK) buttons to increase or decrease the value in \$0.25 increments.
5. When the desired value is displayed, press the RETURN (WHITE) button twice to return to the RUN MODE

D. VOIDING TOKENOTES®

To void unwanted Tokenotes® it is necessary to have three additional Training Coupons; NULL, VENDING CLEAR ONE, and CLEAR ALL. The use of any Tokenote® can be eliminated by one of the three methods described below.

- Use the NULL Training Coupon to continue accepting a particular Tokenote® but stop giving credit for it** (This will erase any value that the Tokenote® had)

VALIDATOR

1. With the power on, check the operation of the changer. A dot flashing on the LED indicates the machine is operating normally.
2. Note the position of each switch on the DIP switch. (The DIP switch is located on the side of the Validator.)
3. Set all 10 DIP switches to the OFF position. Then, starting with Switch #10, slowly move the switches to the ON position, one switch at a time and in decreasing order (10, 9, 8, 7...). The LED should now be flashing the letter "P". This signifies that the Validator is in the Tokenote® Programming Mode.
4. Insert the Tokenote® you no longer wish to credit into the Validator, making sure that it is accepted.
5. Insert the NULL Training Coupon into the Validator, making sure that it is accepted.
6. Repeat Steps 4-5 for each Tokenote® that you no longer wish to give credit for.
7. Starting with Switch #1, slowly move the switches back to their original positions one at a time. This must be done in increasing order (1, 2, 3, 4...). A dot should now be flashing on the LED.

- Use the VENDING CLEAR ONE Training Coupon to stop accepting a particular Tokenote** (This will erase any record that the Tokenote® was ever programmed)

VALIDATOR

1. With the power on, check the operation of the changer. A dot flashing on the LED indicates the machine is operating normally.
2. Note the position of each switch on the DIP switch. (The DIP switch is located on the side of the Validator.)
3. Set all 10 DIP switches to the OFF position. Then, starting with Switch #10, slowly move the switches to the ON position, one switch at a time and in decreasing order (10, 9, 8, 7...). The LED should now be flashing the letter "P". This signifies that the Validator is in the Tokenote® Programming Mode.
4. Insert the Tokenote® you wish to clear into the Validator, making sure that it is accepted.
5. Insert the VENDING CLEAR ONE Training Coupon into the Validator, making sure that it is accepted.
6. Repeat Steps 4-5 for each Tokenote® you wish to void.
7. Starting with Switch #1, slowly move the switches back to their original positions one at a time. This must be done in increasing order (1, 2, 3, 4...). A dot should now be flashing on the LED.

- Use the CLEAR ALL Training Coupon to stop accepting all Tokenotes® already programmed into the Validator** (This erases any record that the Tokenotes® were ever programmed)

VALIDATOR

1. With the power on, check the operation of the changer. A dot flashing on the LED indicates the machine is operating normally.
2. Note the position of each switch on the DIP switch. (The DIP switch is located on the side of the Validator.)
3. Set all 10 DIP switches to the OFF position. Then, starting with Switch #10, slowly move the switches to the ON position, one switch at a time and in decreasing order (10, 9, 8, 7...). The LED should now be flashing the letter "P". This signifies that the Validator is in the Tokenote® Programming Mode.
4. Insert the CLEAR ALL Training Coupon into the Validator, making sure that it is accepted.
5. Starting with Switch #1, slowly move the switches back to their original positions one at a time. This must be done in increasing order (1, 2, 3, 4...). A dot should now be flashing on the LED.

- The following table shows the different types of Training Coupons needed to successfully program Tokenotes® on an Auto Cashier.**

TRAINING COUPONS	
Training Coupon Type	Usage
COUPON #1	Used to program credit for Coupon #1 discount
COUPON #2	Used to program credit for Coupon #2 discount
COUPON #3	Used to program credit for Coupon #3 discount
COUPON #4	Used to program credit for Coupon #4 discount
CLEAR ALL	Used to erase all trained Tokenotes® so that the Validator will no longer accept any Tokenotes®
NULL	Used to accept a particular Tokenote® without giving credit for it (such as an expired note)
CLEAR ONE	Used to erase one or more trained Tokenotes® so that the Validator will no longer accept cleared Tokenotes®

APPENDIX D

FACTORY PROGRAMMED SETTINGS

PROGRAMMABLE OPTIONS	FACTORY SETTINGS
TOKEN COIN MODE	MULTIPLE CREDITS
TOKEN COIN VALUE	\$1.00
TOKENOTE® MODE	MULTIPLE CREDITS
TOKENOTE® VALUE	\$1.25
COUPON #1 VALUE	\$0.25
COUPON #2 VALUE	\$0.50
COUPON #3 VALUE	\$0.75
COUPON #4 VALUE	\$1.00
ITEM #1 PRICE	\$1.00
ITEM #2 PRICE	\$2.00
ITEM #3 PRICE	\$3.00
ITEM #4 PRICE	\$4.00
ITEM #1 NAME	“WASH”
ITEM #2 NAME	“WASH & WAX”
ITEM #3 NAME	“WASH, WAX, & DRY”
ITEM #4 NAME	“SUPER WASH”
PROCEED MESSAGE #1	“THANK YOU”
PROCEED MESSAGE #2	“PLEASE DRIVE AHEAD”
PROCEED MESSAGE #3	“---NOT USED---”
PROCEED MESSAGE #4	“---NOT USED---”
WELCOME MESSAGE #1	“SELECT SERVICE”
WELCOME MESSAGE #2	“OR DEPOSIT MONEY”
WELCOME MESSAGE #3	“--- NOT USED ---”
WELCOME MESSAGE #4	“--- NOT USED ---”
VEND DURATION	2.0 seconds
EMPTY MODE	OUT OF SERVICE
BUILD MODE	LIMIT DISABLED
PAY DEFAULT	OUT OF SERVICE
HOPPER STYLE	NEW STYLE HOPPER
DISPLAY STYLE	REGUALR (20 CHAR)
BUTTON ENABLE	ENABLED

APPENDIX E

PRE-PROGRAMMED ITEM NAMES		
“	WASH	”
“	WASH ONLY	”
“	WAX	”
“	POLISH WAX	”
“	RINSE	”
“	BRUSH	”
“	PRE HEAT	”
“	DRY	”
“	SUPER WASH	”
“	DELUXE WASH	”
“	SUPER RINSE	”
“	WASH & DRY	”
“	WASH & RINSE	”
“	NO SPOT RINSE	”
“	SPOT FREE RINSE	”
“	LEMON WAX	”
“	WASH & LEMON WAX	”
“	SIMONIZE WAX	”
“	WASH & SIMONIZE WAX	”
“	WASH & NO SPOT RINSE	”
“	WASH WAX & RINSE	”
“	WASH & WAX	”

PRE-PROGRAMMED ITEM NAMES (cont...)		
“	DOUBLE WASH & RINSE	”
“	WASH & POLISH WAX	”
“	DOUBLE WASH & POLISH	”
“	DOUBLE WASH & TIRE	”
“	WASH & HOT WAX	”
“	WASH HOT WAX & DRY	”
“	WASH WAX & DRY	”
“	WASH WAX RINSE TIRE	”
“	WASH & SIDEWALL	”
“	WASH WAX & SIDEWALL	”
“	WASH & TIRE	”
“	WASH WAX & TIRE	”
“	WASH HOT WAX & TIRE	”
“	WASH & WHITEWALL	”
“	WASH WAX & WHITEWALL	”
“	UNDERCARRIAGE	”
“	WASH & UNDERCARRIAGE	”
“	UNDER BODY SPRAY	”
“	WASH & UNDER SPRAY	”
“	RUST INHIBITOR	”
“	WASH & RUST INHIBITOR	”
	(BLANK)	

APPENDIX F

PRE-PROGRAMMED PROCEED MESSAGES		
	NOT USED	
“	THANK YOU	”
“	PLEASE DRIVE AHEAD	”
“	PUT CAR IN NEUTRAL	”
“	DO NOT BRAKE/STEER	”
“	PLEASE PROCEED	”
“	DRIVE FORWARD	”

PRE-PROGRAMMED WELCOME MESSAGES		
“	--NOT USED--	”
	CURRENT DAY DATE & TIME	
“	WELCOME	”
“	SELECT ITEM PLEASE	”
“	PLEASE CHOOSE ITEM	”
“	PRESET ITEM BUTTON	”
“	MAKE ITEM SELECTION	”
“	SELECT DESIRED WASH	”
“	ENTER CODE	”
“	OR ENTER CODE	”
“	ENTER TICKET NUMBER	”
“	USE CODE OR CASH	”
“	OR SELECT ITEM	”
“	SELECT ITEM	”
“	SELECT SERVICE	”
“	OR DEPOSIT MONEY	”
“	MAKE SELECTION	”
“	PAY IN CASH OR TOKEN	”
“	USE CASH OR TOKEN	”
“	SELECT WASH	”
“	USE KEYPAD TO CREDIT	”
	(BLANK)	

APPENDIX G

INSTALLATION / MOUNTING INSTRUCTIONS

A curb and base are poured. Form the base according to dimensions on the accompanying drawing. These dimensions will locate the user controls most conveniently. Precisely locate the conduit in the base where they will match the holes in the bottom of the cabinet as shown in the drawing, OR, locate the conduit in a position behind the cabinet if the conduit holes in the rear of the cabinet will be used.

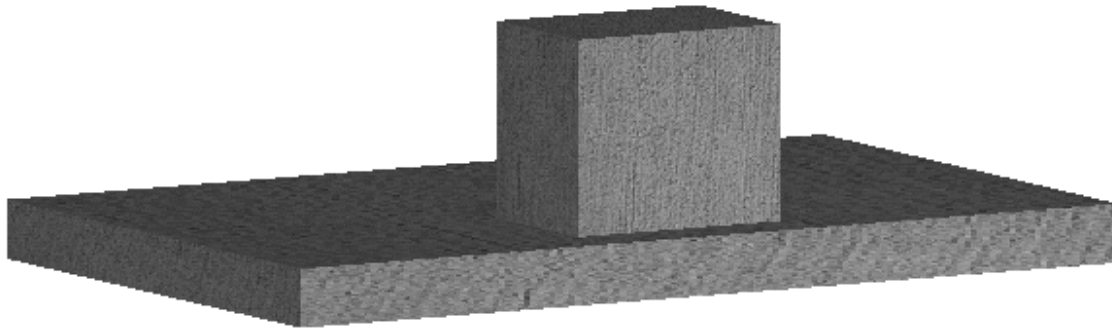

Mount the Auto Cashier onto the concrete base using appropriate fasteners. The mounting hole locations in the cabinet are shown on pages 34 and 35, FIGURE 1 and FIGURE 2.

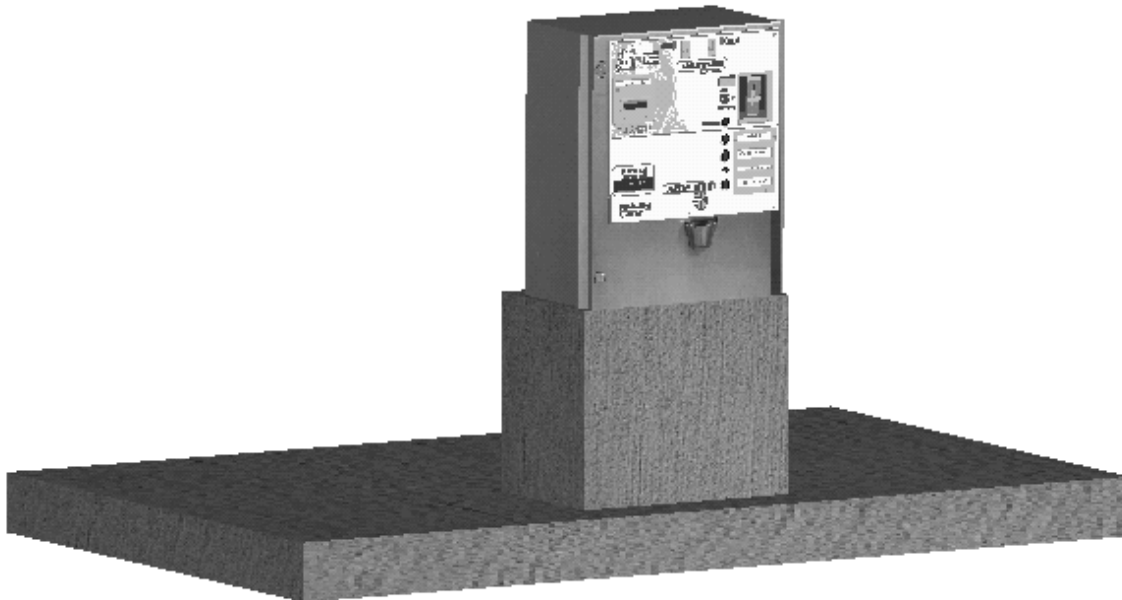

A close-up shows that the concrete base is as wide as the cabinet – including flanges.



Complete conduit connections before completing any masonry work.

Brick in the cabinet and base. Note that fill is required behind the flanges. **DO NOT BRICK OF FILL IN FRONT OF THE FLANGES.** These allow clearance for door opening. Hamilton recommends that masonry is extended a few inches in front of the cabinet.

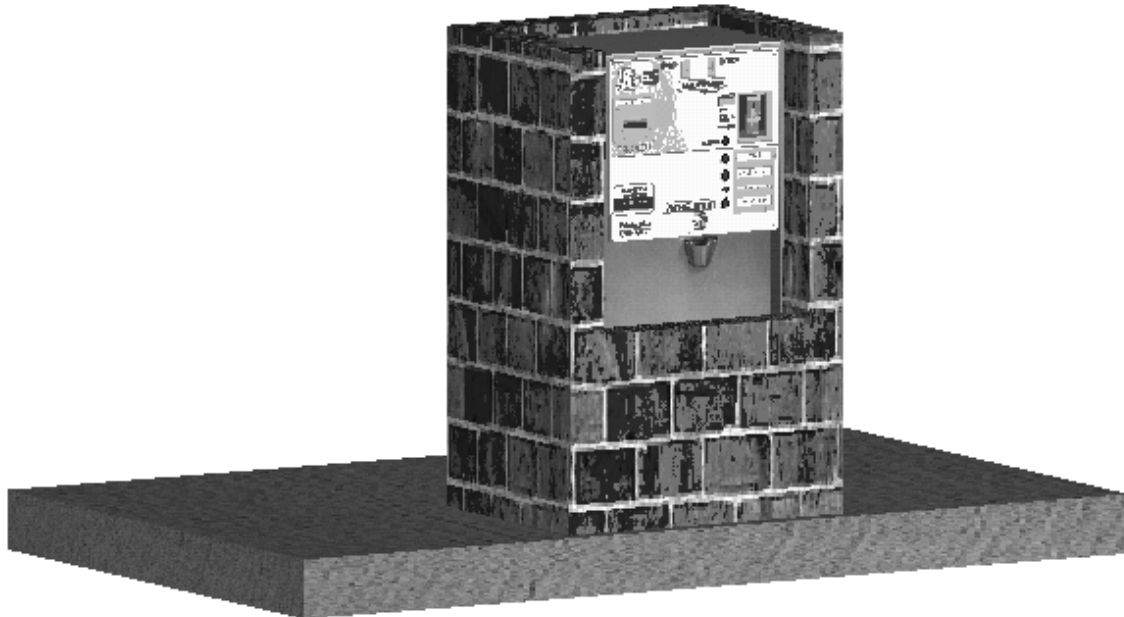

The masonry **MUST** come to height at least $\frac{1}{2}$ inch above the level of the top surface of the cabinet.

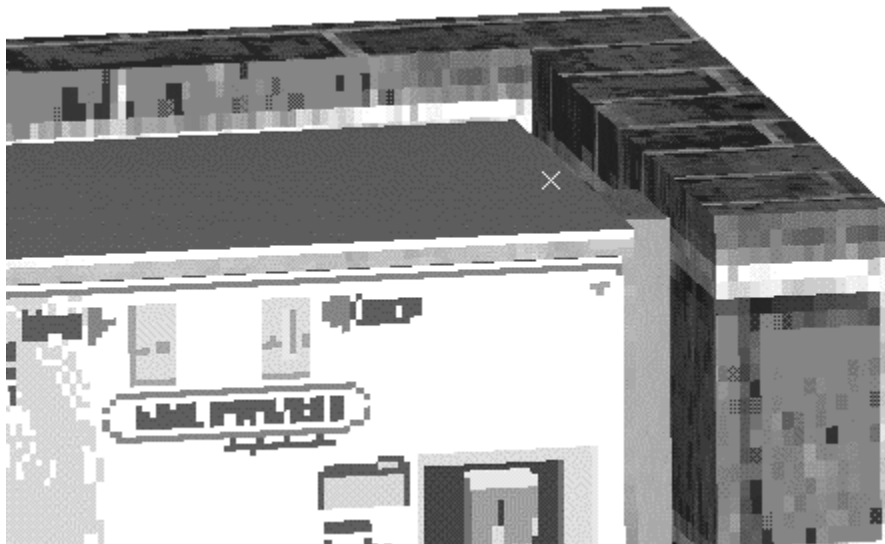

Concrete or mortar is placed on top of the cabinet to the height of the masonry.

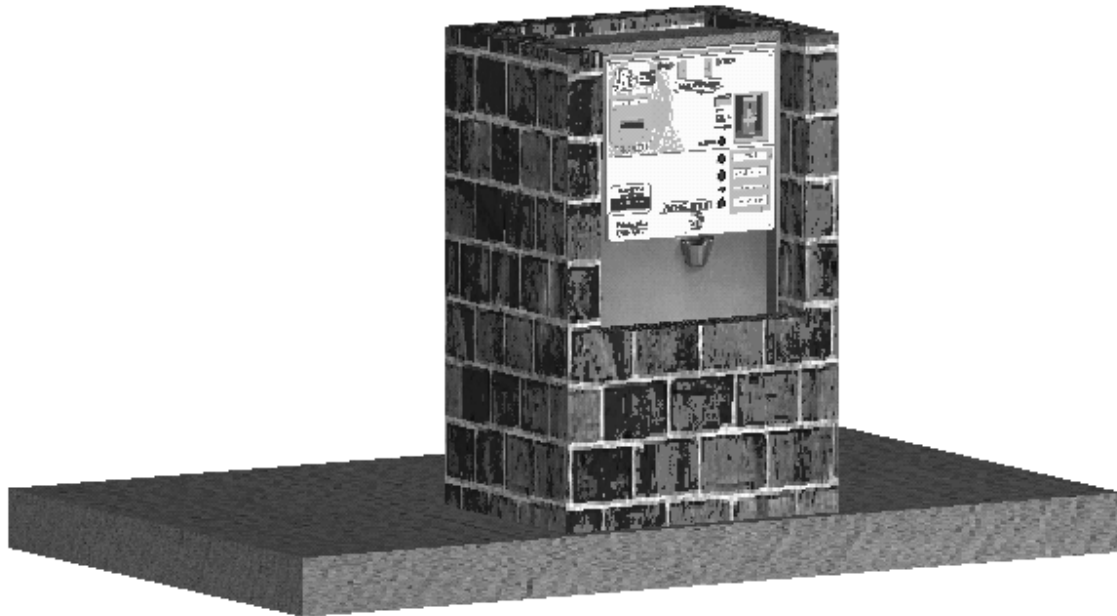

Cap off the construction.

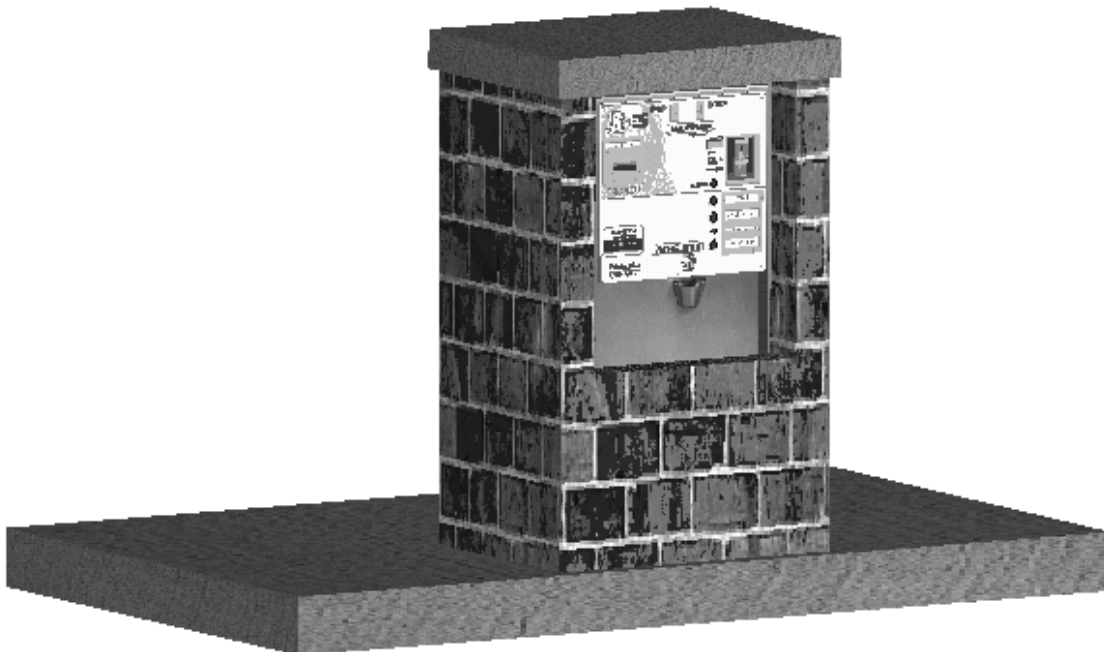

**LIMITED WARRANTY AGREEMENT
OF HAMILTON MANUFACTURING CORP.**

Hamilton Manufacturing Corp., an Ohio Corporation, ("Seller") warrants to Purchaser that all new equipment shall be free from defects in material and factory workmanship for a period of one (1) year from the original shipping date. Hamilton Manufacturing Corp. further warrants if any part of said new equipment in Seller's sole opinion, requires replacement or repair due to a defect in material or factory workmanship during said period, Seller will repair or replace said new equipment. Purchaser's remedies and the liabilities and obligations of Seller herein shall be limited to repair or replacement of the equipment as Seller may choose, and Seller's obligation to remedy such defects shall not exceed the Purchaser's original cost for the equipment. Purchaser EXPRESSLY AGREES this is the EXCLUSIVE REMEDY under this warranty. There are no other express or implied warranties which extend beyond the face hereof. All warranty repair service must be performed by either a Factory Trained Service Representative or **HAMILTON MANUFACTURING CORP., 1026 Hamilton Drive, Holland, Ohio 43528 PHONE (419) 867-4858 or (800) 837-5561, FAX (419) 867-4867.**

The limited warranty for new equipment is conditioned upon the following:

1. The subject equipment has not, in the Seller's sole opinion, been subjected to: accident, abuse, misuse, vandalism, civil disobedience, riots, acts of God, natural disaster, acts of war or terrorism.
2. The Seller shall not be liable for any expense incurred by Purchaser incidental to the repair or replacement of equipment and Purchaser shall assume full responsibility for any freight or shipping charges.
3. The coverage of this warranty shall not extend to expendable parts.
4. Purchaser shall have a warranty registration card on file with Seller prior to any claim in order for warranty protection to apply.
5. No warranty coverage is applicable to any equipment used for currency other than that specified at the time of the purchase.
6. Seller expressly disclaims any warranty that counterfeit currency will not activate said equipment.
7. Seller expressly disclaims any warranty for any losses due to bill manipulation or theft or loss of cash under any circumstances.

Seller further warrants all repair or service work performed by a factory trained representative or Hamilton Manufacturing Corp. for a period of ninety (90) days from the date the repair or service work was performed. Purchaser's remedies and the liabilities and obligations of Seller herein shall be limited to repair or replacement of equipment as Seller may choose, and Seller's obligation to remedy such defects shall not exceed the Purchaser's depreciated value of the equipment. Purchaser EXPRESSLY AGREES this is an EXCLUSIVE REMEDY under this warranty. There are no other express or implied warranties on repair or service work performed by a factory trained representative or Hamilton Manufacturing Corp. which extend beyond the face hereof.

(see next page for additional provisions)

The limited warranty for repair and service work is conditioned upon the following:

1. The subject equipment has not, in the Seller's sole opinion, been subjected to: accident, abuse, misuse, vandalism, civil disobedience, riots, acts of God, natural disaster, acts of war or terrorism.
2. The Seller shall not be liable for any expense incurred by Purchaser incidental to the repair or replacement of equipment and Purchaser shall assume full responsibility for any freight or shipping charges.
3. The coverage of this warranty shall not extend to expendable parts.
4. Purchaser shall have a warranty registration card on file with Seller prior to any claim in order for warranty protection to apply.
5. No warranty coverage is applicable to any equipment used for currency other than that specified at the time of the purchase.
6. Seller expressly disclaims any warranty that counterfeit currency will not activate said equipment.
7. Seller expressly disclaims any warranty for any losses due to bill manipulation or theft or loss of cash under any circumstances.
8. No person or entity other than a factory trained representative or Hamilton Manufacturing Corp. has performed or attempted to perform the subject repair or service.

THIS AGREEMENT IS MADE WITH THE EXPRESS UNDERSTANDING THAT THERE ARE NO IMPLIED WARRANTIES THAT THE EQUIPMENT SHALL BE MERCHANTABLE, OR THAT THE GOODS SHALL BE FIT FOR ANY PARTICULAR PURPOSE. PURCHASER HEREBY ACKNOWLEDGES THAT IT IS NOT RELYING ON THE SELLER'S SKILL OR JUDGMENT TO SELECT OR FURNISH EQUIPMENT SUITABLE FOR ANY PARTICULAR PURPOSE AND THAT THERE ARE NO WARRANTIES WHICH EXTEND BEYOND THAT WHICH IS DESCRIBED HEREIN.

The Purchaser agrees that in no event will the Seller be liable for direct, indirect, or consequential damages or for injury resulting from any defective or non-conforming new, repaired or serviced equipment, or for any loss, damage or expense of any kind, including loss of profits, business interruption, loss of business information or other pecuniary loss arising in connection with this Limited Warranty Agreement, or with the use of, or inability to use the subject equipment regardless of Sellers knowledge of the possibility of the same.

Hamilton Manufacturing Corporation

1026 Hamilton Drive
Holland, OH 43528

Sales Phone: (888) 723-4858 or (419) 867-4858 **Sales Fax:** (419) 867-4850

Service Phone: (800) 837-5561 **Service Fax:** (419) 867-4867

Website: <http://www.hamiltonmfg.com>

Email Addresses:

service@hamiltonmfg.com

sales@hamiltonmfg.com

parts@hamiltonmfg.com

info@hamiltonmfg.com